



# International Ski Mountaineering Federation

---

## Rules for organising international ski mountaineering competitions

---

**Any change requested by the organiser regarding itineraries or schedule in the following regulation has to be presented to and approved by the ISMF technical team in advance.**

*NB: All rules and regulations may be subject to modification of the language used, in so much as the context and the content of the rule/regulation will remain unaltered but the English language used within in said rules and regulations may be subject to improvement in terms of grammar and clarity.*

# INDEX

<b>1. GENERAL REMARKS.....</b>	<b>5</b>
1.1. Race organizers –ISMF meeting.....	5
1.2. LOCs, National Federation and ISMF.....	5
1.2.1. Local Organising Committee (LOC).....	5
1.2.2. Relations between ISMF and LOCs/National Federation (NF).....	5
1.2.3. Agreement between ISMF, the NF and /or the LOC.....	6
<b>2. FINANCE AND ADMINISTRATION.....</b>	<b>6</b>
2.1. Administrative requirements.....	6
2.2. Insurance.....	6
2.3. Budget.....	6
2.4. Costs assumed by the LOC.....	7
2.4.1. ISMF Event hosting fees.....	7
2.4.2. Prize Money and awards.....	8
2.5. Others costs assumed by the ISMF.....	9
<b>3. ORGANISATION.....</b>	<b>9</b>
3.1. LOC Staff.....	9
3.2. Officials.....	9
3.3. Documents prepared by the LOC.....	10
3.3.1. Prior to the competition.....	10
3.3.2. During the competition.....	10
3.4. Organisation locations.....	10
3.4.1. Welcome and registration areas.....	10
3.4.2. Meals and accommodation.....	11
3.4.3. On-site transportation.....	11
<b>4. SPORT AND TECHNICAL ISSUES.....</b>	<b>11</b>
4.1. Competition officials (roles and responsibilities).....	11
4.1.1. The LOC President.....	11
4.1.2. The LOC Race Director.....	11
4.1.3. The LOC Environmental Protection Officer.....	12
4.1.4. The President of the Jury.....	12
4.1.5. The Race Jury Referee.....	13
4.1.6. The ISMF IT –Ranking Manager.....	13
4.1.7. The ISMF Event Manager.....	13
4.1.8. The ISMF Technical Delegate.....	13
4.2. The Race Jury.....	14
4.2.1. Composition.....	14
4.2.2. Role of the Jury.....	14
4.2.3. Jury decisions.....	14
4.3. The starting area and the finish area.....	14
4.3.1. The starting area and the finish area.....	14
4.3.2. Commercial village.....	15
4.3.3. Race headquarters.....	15
4.3.4. Spectators areas.....	15
4.3.5. Press areas.....	15
4.4. Race Organisation.....	15
4.4.1. Race registration.....	15
4.4.2. Race bibs.....	16
4.4.3. Race briefings.....	16
4.4.4. Radio links.....	17
4.4.5. Curtailment.....	17
4.4.6. Event stoppage or cancellation.....	17
4.5. Results.....	18
4.6. Official ceremonies.....	18
4.6.1. General protocol rules.....	18
4.7. Prize money for World Cup and Championships.....	20
4.7.1. World Cup and World/Continental Championships prize money.....	20
4.7.2. General Overall World Cup ranking prize-money.....	20

<b>5. RACES SPECIFICATIONS</b>	<b>21</b>
5.1 General Features of ISMF Races	21
5.2 Race Organisation	22
5.2.1 Course route and markings	22
5.2.2 The Start	25
5.2.2.1 Race schedules and Start Times	25
5.2.2.2 Starting procedure for individual, Team or Vertical races	25
5.2.2.3 Starting procedure for Relay races	26
5.2.2.4 Starting procedure for Sprint races	26
5.2.3 Transition (Change) Area	28
5.2.4 Check Points (CP)	28
5.2.5 Refreshment Point	28
5.2.6 Relay and Hand over Zone	28
5.2.7 The Finish	29
5.2.7.1 The finish procedure	29
5.3 Equipment	29
5.3.1 Equipment inspection	29
<b>6. ENVIRONMENTAL CONCERNS</b>	<b>30</b>
<b>7. RACE SAFETY</b>	<b>30</b>
7.1 Rescue and emergencies	31
7.2 Medical organisation	31
7.3 Safety committee	31
<b>8. MEDIA AND BROADCAST RIGHTS</b>	<b>32</b>
<b>9. ADVERTISING RIGHTS</b>	<b>32</b>
9.1 Services and consideration on advertising rights	33
9.2 Intellectual property	33
9.3 Event Publications	33
9.3.1 Use by Event Sponsors	34
9.3.2 The event program	34
<b>10. COMMUNICATION – PRESS AND MEDIA</b>	<b>34</b>
10.1 The LOC Press Officer	34
10.1.1 The LOC Press Officer	34
10.1.2 Press kit	35
10.1.3 The Press releases by the LOC	35
10.1.4 Press conferences	35
10.1.5 Journalists and photographers	35
10.1.6 Acknowledgements	35
10.1.7 LOC and ISMF guests	35
<b>11. THE FIGHT AGAINST DOPING</b>	<b>36</b>
11.1 Doping Control Programme	36
11.2 Doping Control Station (Reminder of basic obligations)	37
11.2.1 Test area	37
11.2.2 The waiting room/area	37
11.3 The staff: the DCOs, the “Chaperones”, the person in charge of Anti-Doping from the LOC	37
11.3.1 The DCOS	37
11.3.2 The “Chaperones”	37
11.3.3 The person in charge of Anti-Doping from LOC	38
11.4 Number of the tests and selection of athletes to be tested	38
<b>12. APPENDIX 1: ACCREDITATION PLAN FOR AN ISMF WC/WCh/Continental event</b>	<b>38</b>
<b>13. APPENDIX 2: ACCREDITATION PLAN – EXAMPLE</b>	<b>39</b>
<b>14. APPENDIX 3: START AREA INDIVIDUAL RACE (AND TEAM RACE)</b>	<b>40</b>
<b>15. APPENDIX 4: START AREA INDIVIDUAL RACE (AND TEAM RACE)</b>	<b>41</b>
<b>16. APPENDIX 5: FINISH AREA INDIVIDUAL RACE (AND TEAM RACE)</b>	<b>42</b>
<b>17. APPENDIX 6: START AREA VERTICAL RACE</b>	<b>43</b>
<b>18. APPENDIX 7: FINISH AREA VERTICAL RACE</b>	<b>44</b>
<b>19. APPENDIX 8: START AREA SPRINT RACE (AND TEAM RELAY RACE)</b>	<b>45</b>



20	APPENDIX 9: FINISH AREA SPRINT RACE (AND TEAM RELAY RACE)	46
21	APPENDIX 10: INFLATABLE ISMF FOR START AND FINISH AREA	47
22	APPENDIX 11: BIBS	48
23	APPENDIX 12: WORLD CUP AND WORLD CHAMPIONSHIPS SCHEDULE	49
24	APPENDIX 13: FOOTAGE ISMF/INFRONT	50
25	APPENDIX 14: CHANGE AREA INDIVIDUAL RACE (AND TEAM RACE)	51
26	APPENDIX 15: SCENIC VIEW INDIVIDUAL RACE (AND TEAM RACE)	52
27	APPENDIX 16: INTERMEDIATE AREA VERTICAL RACE	53
28	APPENDIX 17: CHANGE AREA SPRINT RACE (AND TEAM RELAY RACE)	54
29	APPENDIX 18: DOWNHILL SPRINT RACE (AND TEAM RELAY RACE)	55
30	APPENDIX 19: PART ON SKIS SPRINT RACE (AND TEAM RELAY RACE)	56
31	APPENDIX 20: PART ON FOOTS SPRINT RACE (AND TEAM RELAY RACE)	57
32	APPENDIX 21: LOGOS OF ISMF SKI MOUNTAINEERING WORLD CUP	58
33	APPENDIX 22: OFFICIAL PUBLICATION OF THE EVENT	59
34	APPENDIX 23: OFFICIAL TIMING DATA	60
35	APPENDIX 24: CHECK LIST DEFINING ELEMENTS INCLUDED IN THE AGREEMENT AND RULES	61
36	APPENDIX 25: DOPING CONTROL STATION LAYOUT	62
37	APPENDIX 26: SPECIAL MOTION FOR ASIA (CHINA AND SOUTH KOREA)	63
	<b>TECHNICAL APPENDIX:</b>	<b>64</b>
38	APPENDIX 27: TECHNICAL SPECIFICATIONS START AREA	65
39	APPENDIX 28: TECHNICAL SPECIFICATIONS FINISH AREA	66
40	APPENDIX 29: ALTIMETRIC PROFILE and DESIGN OF THE SPRINT	67
41	APPENDIX 30: SPRINT RACE QUALIFICATION BOARD	68
42	APPENDIX 31: EXAMPLE OF SPRINT RACE SCHEDULE	69
43	APPENDIX 32: RELAY HAND OVER ZONE	70
44	APPENDIX 33: REFRESHMENT POINT	71
45	APPENDIX 34: CONTROL SHEET	72
46	APPENDIX 35: FINISH CONTROL SHEET	73

## 1. GENERAL REMARKS

---

For general introduction, abbreviations, definitions and type of events, see SPORTING RULES (pages 4-5).

### 1.1. Race organisers – ISMF meetings

---

The organisers of events selected for the calendar of the upcoming season will be invited to attend the ISMF Forum (place and dates to be specified in due course, with at least one month's notice).

The meeting takes place at the end of September/beginning of October, with members of the ISMF Council, Sport Department, media partners and other race organisers (new regulations - exchange views with ISMF members and other race organisers, training those responsible for the race route and volunteers).

The presence of World Cup and World and Continental Championships organisers, as well as the judges/referees who will be working on those races, is compulsory. ISMF officials and race organisers will meet to discuss the race and decide certain key issues together.

### 1.2. LOCs, National Federations and ISMF

---

#### *1.2.1 Local Organising Committee (LOC)*

The administrative and legal statutes of LOCs are under the responsibility of the national federation that registers the event. The ISMF headquarters must be informed of the internal structure of the LOC organisation and of the persons in charge of each of the areas mentioned in this document. The Organising Committee is the group of persons or the entity which executes the right, duties and obligations related to the organisation of the ski mountaineering World Cup, World Championships, Continental Championships or Series event. Organiser means the person, group or entity that makes the necessary preparations and directly carries out the running and financing of the Competition as a principle, the National Federation ensures the proper organization of the Competitions/Event and may delegate all or certain tasks, rights and obligations related to the Organization of the Competitions to an affiliated club or another legal entity which then becomes the Organizer and party to any agreements made with the ISMF. All members of the LOC shall have the appropriate competence and experience necessary to carry out their assigned duties. The LOC shall use the ISMF official language (English) in all official documents and meetings (official programme, team captain's meetings, jury meetings, LOC meetings with international participation, etc.).

The Event and the Competitions shall be organized in strict compliance with the applicable ISMF Rules at present in force or amended by the ISMF from time to time, in particular the Statutes and the ISMF Rules. The LOC shall follow the reasonable instructions given by the ISMF.

The LOC shall provide all necessary infrastructures, support and services (including power supply) necessary for the proper organization of the entire event.

The LOC shall establish the Organizing Committee to carry out the tasks, rights and obligations defined in this agreement and in the ISMF Rules. The establishment of the Organizing Committee shall not affect the liability of the LOC.

#### *1.2.2 Relations between ISMF and LOCs/National Federations (NF)*

The LOC must name a person who will act as the official liaison between the organisation and the ISMF.

Relations between ISMF and the LOC/NF will initially be carried out by the ISMF Event Manager and the Vice President for Sport and Event, and then also with the chairman of the ISMF jury once he/she has been appointed.

The LOCs of ISMF World Cup, World Championships, European Championships must follow all the ISMF regulations maintaining close coordination with the ISMF offices and various responsible entities. The NF appoints the LOC to carry out the duties and responsibilities connected with organizing the event. The NF has delegated the tasks, rights and obligations related to the Organisation of the event to the LOC. All aspects defining the mutual obligations between ISMF/NF and/or LOC will be defined in a specific contract with the ISMF.

After the ISMF forum, the LOC must make a monthly report to the ISMF with updates on general organisation, any outstanding issues, and commitments to be fulfilled. Minutes of LOC meetings must be sent to the ISMF office.

### 1.2.3 Agreement between ISMF and the NF and/or LOC

An agreement will be signed between the ISMF, the NF and/ or the LOC. This agreement will specify:

- Definitions and general conditions
- Appointment of the Organiser
- General obligation of the LOC
- The Organising Committee
- Technical and special conditions
- The event schedule
- The event venue
- The personnel liaising with national teams
- The accreditation system
- The equipment
- Timing and data
- Press and media
- Financial aspects
- Multimedia rights
- TV production
- TV production assistance
- Advertising rights
- Services and consideration on advertising rights
- Intellectual property
- The event programme
- Representations and warranties
- Environmental/Sustainability aspects
- Medical services
- Insurance
- ISMF assistance
- Termination and consequences thereof
- Budgetary and financial obligations.

Any arrangements that are not provided for in the initial agreement will be settled by amendments between the NF, the LOC and ISMF.

## 2. FINANCE AND ADMINISTRATION

---

### 2.1. Administrative requirements

---

The LOC and the NF must take all necessary and useful administrative measures to ensure that the event takes place in the best possible conditions (aid and rescue, environmental issues, etc.).

### 2.2 Insurance

---

The NF and/or the LOC must have adequate insurance as required in the host country to cover all civil liability risks. The coverage shall include all members of the LOC and of the Jury, including the ISMF representatives. The minimum liability insurance amount shall be CHF 3.000.000 (three million Swiss Francs) for each incident. The ISMF will take care of full insurance coverage of the civil liability of the officers and staff members attending the event on behalf of the ISMF who are not members of the Organizing Committee and of the Jury. The insurance coverage shall apply from the day before the first training day until (and including) the last day of the Event. The Organizer shall submit a copy of the relevant insurance policy to the ISMF Event Manager prior to the Event.

### 2.3 Budget

---

The budget (inflows and outflows) is the sole responsibility of the NF or the LOC. The NF and/or the LOC assume the event's financial risk, being entirely responsible for any losses and /or deficit, whilst also retaining any surplus in the event of a budget benefit.

The NF and/or the LOC must also abide by national legislation with respect to the payment of any local and /or national taxes that may apply to the event.

## 2.4 Costs assumed by the LOC

### 2.4.1 ISMF Event hosting fees

The NF and/or the LOC assumes all organizational costs, with the exception of those assumed directly by ISMF (§2.5). The LOC assumes the following costs that are paid directly to the ISMF.

ISMF WORLD CUP AND CHAMPIONSHIPS HOSTING FEES						
SERVICES				WORLD CUP (2 or 3 DAYS)	WORLD CHAMPIONSHIPS	CONTINENTAL CHAMPIONSHIPS
Calendar fee				YES	YES	YES
Anti-doping service				YES	YES	YES
Time – keeping service				YES	YES	YES
Awards				YES	YES	YES
Online registration through ISMF web site				YES	YES	YES
Ranking manager supervision				YES	YES	YES
Ski pass if the race takes place in a ski resort				YES	YES	YES
<ul style="list-style-type: none"> <li>2 ski passes for each national team per day of competition + 1 day (the day before the competition),</li> <li>1 ski pass for each ISMF official per day of competition + 1 day (the day before the competition)</li> <li>1 ski pass for each persons of TV Team, Implementation Team, Time Keeping Team per day of competition + 1 day (the day before the competition)</li> </ul>						
ISMF PRESENCE	TRANSPORT EXPENSES	FINANCIAL ALLOWANCES	ACCOMODATION EXPENSES	WORLD CUP (2 or 3 DAYS)	WORLD CHAMPIONSHIPS	CONTINENTAL CHAMPIONSHIPS
ISMF referee President of jury	Included <sup>1</sup>	Included <sup>1</sup>	Full board accommodation <sup>2</sup>	YES	YES	YES
ISMF referee 1	Included <sup>1</sup>	Included <sup>1</sup>	Full board accommodation <sup>2</sup>	YES	YES	YES
ISMF – referee 2	Included <sup>1</sup>	Included <sup>1</sup>	Full board accommodation <sup>2</sup>	YES	YES	YES
ISMF Event Manager	Included <sup>1</sup>	Included <sup>1</sup>	Full board accommodation <sup>2</sup>	YES	YES	YES
ISMF Technical Delegate	Included <sup>1</sup>	Included <sup>1</sup>	Full board accommodation <sup>2</sup>	YES	YES	YES
ISMF IT-ranking manager	Included <sup>1</sup>	Included <sup>1</sup>	Full board accommodation <sup>2</sup>	NO	YES	NO <sup>3</sup>
ISMF Council delegate	-	-	Full board accommodation <sup>4</sup>	YES	YES	YES
TV Production Team (5 persons)	Included <sup>1</sup>	Included <sup>1</sup>	Full board accommodation <sup>2</sup>	YES	YES	YES <sup>5</sup>
Implementation Team (4 persons)	Included <sup>1</sup>	Included <sup>1</sup>	Full board accommodation <sup>2</sup>	YES	YES	YES <sup>5</sup>
Time - keeping team (4 persons)	Included <sup>1</sup>	Included <sup>1</sup>	Full board accommodation <sup>2</sup>	YES	YES	YES <sup>5</sup>
Speaker (1 person)	included	included	Full board accommodation <sup>2</sup>	YES	NO	NO

All fees are paid by the LOC directly to the ISMF. **The exact amount will be established annually and officially announced during the autumn forum.**

FREE SERVICES ADDITIONALLY PROVIDED BY ISMF	TRANSPORT EXPENSES	FINANCIAL ALLOWANCES	ACCOMODATION EXPENSES	WORLD CUP (2 or 3 DAYS)	WORLD CHAMPIONSHIPS	CONTINENTAL CHAMPIONSHIPS
Highlight TV production	-	-	5 people full board accommodation <sup>2</sup>	YES	YES	YES <sup>5</sup>
Official Photographer	-	-	Full board accommodation <sup>2</sup>	YES	YES	YES <sup>5</sup>
Race Press Office	-	-	-	YES	YES	YES <sup>5</sup>
Advertising Implementation	-	-	2 people full board accommodation <sup>2</sup>	YES	YES	YES <sup>5</sup>

1 All transport expenses from home to the competition venue except extra costs of extra-continental travel, plus daily allowance for duration of event + 1

Costs not included in the chart above have to be covered by the LOC:

2 Accommodation expenses (food and lodging) from two nights before the start of the first race until the morning following the end of the event, details to be communicated in due advance. Minimum 3 stars (three-star) hotel with complimentary Internet connection (single and double rooms)

- 3 Except for the finals of the Junior/Espoir and Senior World Cup where the ISMF IT-ranking manager is requested  
 4 Accommodation expenses (food and lodging) from one night before the start of the first race until the morning following the end of the event, details to be communicated in due advance. Minimum 3 stars (three-star) hotel with complimentary Internet connection (single room)  
 5 Solely if when held on the same dates and at the same venue of a World Cup week-end or, alternatively, only with specific agreement before the relevant ski season for the proper management of the event

ISMF SERIES / TECHNICAL VISIT FEE						
ISMF SERIES	ISMF PRESENCE	TRANSPORT EXPENSES	FINANCIAL ALLOWANCES	ACCOMODATION EXPENSES	ISMF ONLINE REGISTRATIONS	ISMF/INFRONT MEDIA COVERAGE
Calendar fee 500€ within Europe 200€ outside Europe	1 member of ISMF Sport Department	500 € within Europe Exact costs outside Europe	150€ per competition day + 1 (extra days can be requested)	Full board accommodation <sup>2</sup> (see above)	OPTIONAL	NO (except ISMF website and social networks)

## 2.4.2 Prize Money and awards

PRIZE MONEY (minimum)	WORLD CHAMPIONSHIPS					WORLD CUP/ CONTINENTAL CHAMPIONSHIPS			
	SPRINT	VERTICAL	INDIVIDUAL	TEAM	RELAY	SPRINT	VERTICAL	INDIVIDUAL	TEAM
1 <sup>st</sup> SM/SW	1500 €	1500 €	1500 €	2000 €* <sup>*</sup>	2000 €* <sup>*</sup>	1100 €	1100 €	1100 €	1400 €* <sup>*</sup>
2 <sup>nd</sup> SM/SW	1000 €	1000 €	1000 €	1300 €* <sup>*</sup>	1300 €* <sup>*</sup>	825 €	825 €	825 €	1000 €* <sup>*</sup>
3 <sup>rd</sup> SM/SW	700 €	700 €	700 €	900 €* <sup>*</sup>	900 €* <sup>*</sup>	575 €	575 €	575 €	700 €* <sup>*</sup>
4 <sup>th</sup> SM/SW	-	-	-	-	-	400 €	400 €	400 €	-
5 <sup>th</sup> SM/SW	-	-	-	-	-	200 €	200 €	200 €	-
1 <sup>st</sup> EM/EW	500 €	500 €	500 €	-	-	Prize money or its equivalent in equipment			
2 <sup>nd</sup> EM/EW	300€	300 €	300 €	-	-	Prize money or its equivalent in equipment			
3 <sup>rd</sup> EM/EW	200€	200 €	200 €	-	-	Prize money or its equivalent in equipment			
Top 3 JM/JW	Prize money or its equivalent in equipment					Prize money or its equivalent in equipment			
Top 3 CM/CW	Prize money or its equivalent in equipment					Prize money or its equivalent in equipment			
TOTAL/category	4200 €	4200 €	4200 €	4200 €	4200 €	3100 €	3100 €	3100 €	3100 €
TOTAL Men and Women	42000 €					6200 €	6200 €	6200 €	6200 €

\* the amount has to be considered per team

The LOC guarantees the minimum prize-money in connection with each competition according to the ISMF Rules. The LOC is however entitled to pay out a higher than the minimum prize – money. Each podium athlete should receive an award and not just a handshake (something typical of the venue, the country, the valley etc.).

If the prize money is not given in cash during the prize-giving ceremony, the LOC must make a bank transfer no more than 1 week after the end of the event.

**The top five athletes of each category** (or as per rules according to number of participants) will be called to the podium during the official prize giving ceremony.

The LOC race may invite foreign athletes at their own expense. To be invited to participate in a race, athletes must:

- hold the national license of an ISMF federation member;
- the federation member has to be up to date with all ISMF fees;
- hold an ISMF international license for the current season.

In case of cancellation of an event (for all ISMF races), the LOC is still responsible of all the following costs:

- ISMF registration fee;
- Anti-doping fee;
- All travelling/accommodation costs already engaged by the members of the ISMF staff.

In special circumstances, and with the prior agreement of the ISMF, a race may award both Continental Championship and World Cup titles for the same competition. In this case, two podiums will be held, however, the prize money will only be awarded to the World Cup race.

## 2.5 Others costs assumed by ISMF

ISMF covers the expenses and services for:

FREE SERVICES ADDITIONALLY PROVIDED BY ISMF	WORLD CUP	WORLD CHAMPIONSHIPS	CONTINENTAL CHAMPIONSHIPS	ISMF SERIES
Highlight TV production	YES	YES	YES <sup>1</sup>	NO
Official Photographer	YES	YES	YES <sup>1</sup>	NO
Race Press Office	YES	YES	YES <sup>1</sup>	NO
Advertising Implementation	YES	YES	YES <sup>1</sup>	NO
World Cup final trophies (overall ranking)	<b>Trophies for the first three competitor of each category</b> (men and women; senior, espoir, junior and cadets)	NO	NO	NO
Medals (gold, silver and bronze)	NO	YES	YES	NO
Bib	YES	YES	YES	NO

<sup>1</sup> Solely when held on the same dates and at the same venue of a World Cup week-end or, alternatively, only with specific agreement before the relevant ski season for the proper management of the event

## 3. ORGANISATION

### 3.1. LOC staff

All persons involved in the organisation of a competition are named "members of the organisation". A list of names will be drawn up, communicated to the ISMF and displayed on the race organisation's website.

A typical LOC is composed of:

- the president of the national federation or his/her representative;
- the organising committee president;
- the race director;
- the treasurer;
- the administrative officer (registration, accreditations, ski passes, interpreter, etc.);
- the press officer (press and media relations, communication);
- the environmental protection officer;
- a person in charge of ALL communication with ISMF
- a person in charge of results;
- a person in charge of catering and accommodation;
- a person in charge of the awards ceremonies;
- a person in charge of site management and equipment;
- a doctor and rescue team.

### 3.2. Officials

Race officials are:

- the president of the NF or his/her representative;
- the president of the LOC;
- the LOC race director;
- the president of the jury (ISMF);
- the race jury referee (ISMF);
- the head LOC trail director;
- the LOC environmental protection officer;
- the LOC press officer;
- NF delegates;
- ISMF officials (ISMF Sport & Event delegate, ISMF Event Manager, ISMF Technical Delegate, members of the ISMF Council).

The roles and responsibilities of these officials are described in § 4.1. Trainers, team managers and competitors cannot be race officials. Members of the ISMF jury appointed for a given race may not compete in said race.

### 3.3. LOC Documentation

---

#### 3.3.1 Prior to the competition

**On the website before 15th November of the current season - A translation of the information into English is mandatory.**

- The LOC must publish documentation giving general information about the event for athletes, the national federation, ISMF and the press. This document should contain the following elements:
  - the programme: schedules, registration location, briefings, routes, meals, etc.;
  - courses: types of courses and differences in height;
  - any supplementary equipment required (see Sporting Rules);
  - contact information (phone, email, fax);
  - information on how to reach the venue (by car or public transport); accommodation, etc.
- Registrations are carried out directly via internet on the ISMF website (access to ISMF registration will be supplied to every organiser). Registrations usually close a minimum of 2-3 days before the race.
- To prepare a location and have the necessary means for taking samples for anti-doping controls, as provided in the texts of the WADA-AMA and the National Agency.
- The LOC sets a deadline for race and accommodation registration
- It is **mandatory** to issue official passes to athletes, race personnel and members of the press (please refer to list)
- In the event of an adjournment due to bad weather conditions, the national federations, in consultation with the ISMF, should do everything within their power to ensure participation on the day scheduled for the adjournment, if this was an inherent part of the event programme (as agreed in advance with the ISMF).
- The LOC is required to pay an advance of the event hosting fee, exact details provided to each event individually.
- In the event of cancellation, the LOC has to refund a portion of the hosting fees, exact details provided to each event individually.
- In the event of race cancellation, the LOC is required to refund 50% of any race registration fees paid by national federations

#### 3.3.2 During the competition

At the welcome and registration area, the LOC must provide:

For competitors:

- the event programme;
- a course map and profile (scale 1:25 000 or to nearest possible) showing the route, starting and finishing areas, checkpoints, difficult passages and first-aid posts).

For officials, team managers and members of the press:

- official passes for permanent or temporary access to certain competition areas;
- the event programme, course maps and profiles;
- a list giving contact details (phone numbers) of LOC members, brochures and press releases;
- the provisional world cup ranking, as well as the permanent world ranking;
- ski passes, if necessary.

For the event programme, official passes (accreditation plan) see Appendix 1 and Appendix 2.

### 3.4. Organisation locations

---

The LOC must structure the event around the following locations:

#### 3.4.1. Welcome and registration areas

Welcome and registration offices should be easy to find, (Clearly sign-posted, including ISMF logo) upon entering the resort, being at the same location or very close to each other.

**At least one fluent English speaker must be present at the welcome area and at the briefing.**

The following procedures are performed in these locations:

- general welcome to: athletes, officials, guests, sponsors, members of the press, spectators, etc.;
- distribution of official passes and documents as mentioned above (§ 3.3.2).

Welcome and Registration areas must have notice boards displaying the following:

- a list of members of the organisation and officials (§ 3.1 and 3.2);
- the full event programme;
- descriptions of the race routes;
- the following documents: ISMF International Ski Mountaineering Sporting and Ranking Rules.

A place where competitors equipment can be checked, should they have any doubts, as well as confirming the safety equipment required by the LOC - presence of an ISMF referee.

Alcoholic drinks cannot be offered in the race pack.

### *3.4.2. Meals and accommodation*

The LOC must organise and be financially responsible for catering and accommodation for the duration of the event for the ISMF personnel.

The LOC may organise all accommodation and meals to teams with a set rate ONLY in the event it can offer equal conditions to all delegations.

The LOC must present delegations with a list of accommodation (hotels, apartments, guest houses, etc.) as close as possible to the competition location with negotiated price rates:

- “Normal standard” accommodation with a negotiated price of 50 € maximum including breakfast. Standard must include bathroom and toilet in room for 2-3 people and have access to WI-FI.
- “Higher standard” accommodation.

Information on the tourist board or assistance with regards to accommodation should be included in the general information document (§3.3.1).

### *3.4.3. On-site transportation*

Any planned transport for competitors and accompanying persons, officials, guests and members of the press, should be coordinated by the LOC (if there is a charge this should be clearly indicated).

Road access to the start or arrival area of the race should always be correctly cleared of snow. In case of icy roads and requiring the use of special automobile equipment (winter tire chains), it must be indicated on the competition venue the days prior to the competition.

A big car park near the start area of the race has to be reserved for racers, coaches and organisation members. The LOC should consider organising transport between the closest airport and the race location, in which case, the cost of transport should be indicated on the registration form.

## **4. SPORT AND TECHNICAL ISSUES**

---

### **4.1 Competition officials (roles and responsibilities)**

---

N.B.: competitors, trainers and team managers cannot be officials.

The official team management will be charged €50 in the event of showing disrespect to any event participants(jury, officials, competitors, organisers).

#### *4.1.1 The LOC President*

He/she is in charge of the event for the NF and is the main contact person for the ISMF.

#### *4.1.2 The LOC Race Director*

- His/her appointment must also be sanctioned by the national federation hosting the event;
- He/she is in charge of all technical issues relating to the competition;
- He/she organises the sporting event according to the ISMF document: "Rules for organising ski mountaineering competitions" and other ISMF regulations;
- He/she has the responsibility of ensuring that the course respects the rules laid down in §4.2 to 4.3;
- He/she decides whether the event takes place depending on conditions prior to the event (trails, weather, snowfall, etc.);
- He/she has the responsibility of stopping the competition in the event of accident, danger, adverse weather conditions, etc.;
- He/she is responsible for evacuating all participants: competitors, technical staff and also spectators;
- He/she is in constant contact with the members of the jury, referees, the LOC president, the ISMF staff and the environmental protection officer;
- He/she decides where areas for removing and replacing skins should be positioned, and which techniques should be used for safety reasons (sections on foot, with crampons, etc.).
- He/she can request the assistance of the ISMF staff at any time (referees, TD or others).

#### 4.1.3 The LOC Environmental Protection Officer

- He/she is appointed by the national federation hosting the event;
- He/she has the responsibility of ensuring that the host countries and ISMF environmental protection regulations are enforced (§5);
- He/she works in collaboration with the *president of the jury* to guarantee respect of the environment;
- He/she will supervise the observance of the ISMF texts (regulations) regarding the environment
- He/she is familiar with local environmental issues;
- He/she is familiar with the realities of ski mountaineering competitions;
- He/she is involved in preparing and running the event;
- He/she may, if necessary, consult environment experts;
- He/she is in charge of obtaining environmental approval and ensuring it is respected;
- He/she shall write a short report on the environmental impact of the event and sends it to the LOC.

#### 4.1.4 The President of the Jury

- He/she is appointed by the ISMF referee manager;
- He/she is an international ISMF referee;
- He/she is the highest ISMF official during the race;
- He/she coordinates relations between ISMF and the LOC prior to the event;
- Once appointed, he/she contacts the LOC, follows the organisation of the event and replies to any requests from the LOC;
- He/she ensures that ISMF regulations are followed and resolves any registration issues (categories, etc.);
- He/she ensures, together with the LOC and the environmental protection officer, that the event is run in respect of the environment thus complying with ISMF resolutions;
- He/she ensures that Olympic regulations concerning anti-doping are followed;
- He/she coordinates work carried out by other ISMF delegates;
- He/she has the responsibility to approve the protocol drawn up by the LOC;
- He/she is in charge of relations with the representatives of the national federation;
- He/she has to go through (or make his/her assistants go through) the complete circuit of the competition so that drawing, beaconing, organisation of control points and passages are in accordance with the current ISMF regulation.
- He/she must attend safety committee meetings;
- He/she attends race meetings;
- He/she ensures sporting fairness;
- He/she calls for jury meetings to set up and organise the jury's work and revise ISMF regulations before the event;
- He/she coordinates referees throughout the duration of the event;
- He/she takes the decisions concerning any disputed points or issues that are not provided for in ISMF "Sporting and Ranking rules";
- He/she is in constant contact with the LOC (race director) during the event;
- He/she supervises provisional ranking, and performs an initial verification with the international referees once he/she has received the provisional results,
- He/she applies the penalties and sign the results, and request provisional results as soon as possible
- He/she receives claims submitted within the correct deadline as specified in "International Ski Mountaineering Sporting Rules";

- He/she signs official rankings, gives copy to the ISMF delegate, the ISMF Technical Delegate and the LOC for official posting;
- If the IT-ranking manager is not present at the event, he/she must rapidly send the competition results by e-mail to the IT-ranking manager and ISMF secretary office;
- He/she writes an official report, within 48 hours, addressed to the ISMF Technical Delegate, the responsible of the referees, the ISMF Council and the LOC.
- He/she can advise the LOC on technical issues/requirements.

#### *4.1.5 The ISMF Race Referee*

- He/she is appointed by the ISMF referee manager;
- He/she is an international ISMF referee; the ISMF referee manager will inform the LOC of his/her appointment;
- He/she carries out the tasks assigned by the president of the jury;
- He/she ensures that the event is run according to ISMF regulations;
- He/she attends LOC technical meetings.
- He/she can advise the LOC on technical issues/requirements.

#### *4.1.6 The ISMF IT-Ranking Manager*

*(only in World / European Championships and in the last race of the World Cup (Senior and Youth))*

- He/she provides the LOC with the list of competitors with licences from each national federation a week before the competition, and then again 24 hrs before the competition;
- He/she updates computerized data on the competitors taking part in the event;
- He/she updates official ISMF rankings;
- He/she requests for help from the LOC to set up and coordinate the computerized system by which he/she can immediately receive data from the finish line;
- He/she produces computerized event rankings;
- He/she posts results on the official website and sends them to the referee manager and ISMF headquarters;
- He/she makes sure that each person in charge of a national team receives a copy of rankings for the event;
- He/she is necessarily present at championships and cup finals.

#### *4.1.7 The ISMF Event Manager*

Is the Technical Delegate of all ISMF sporting calendar events. He/she must verify and monitor the compliance by the LOC of the ISMF Rules regarding the organization of the event. The LOC must comply with all provisions of the ISMF Event Manager.

- He/she carries out responsibilities as outlined in the ISMF and LOC agreement;
- He/she is responsible for liaising with organisers/national federations, technical delegates and appointed referees concerning the general management of the event both prior and during the event;
- He/she is the person responsible for relations with the person in charge of the National Federation;
- He/she is not a member of the jury but can attend the meetings of the jury, without right to vote;
- He/she can act as representative of the ISMF president;
- He/she is the person responsible for providing the person in charge of the protocol with any ISMF cups, trophies or medals;
- He/she assures that prize giving ceremony protocol is carried-out;
- He/she acts as ISMF liaison to help ensure the correct *organisation* of doping controls protocol;
- He/she is responsible for the relations with the representative of the organisation of the sport event.

#### *4.1.8. The ISMF Technical Delegate*

He/she is a technical consultant of the ISMF responsible for the technical organization of the event, working in close collaboration with the LOC Race Director.

## 4.2 The Race Jury

---

### 4.2.1 Composition

For all competitions, World Championships, Continental Championships and World Cup races, a race jury is formed. The jury only meets at the request of the president of the jury.

The jury is composed of:

- the president of the jury appointed by ISMF (right to vote);
- the LOC race director (right to vote);
- the LOC trail director (no vote);
- the first international referee (right to vote);
- the second international referee (right to vote) only for World or European Championships the ISMF IT-ranking manager (no vote if present at the race);
- an ISMF Council Delegate (no vote).

The ISMF Event Manager and the ISMF Technical Delegate will participate in meetings and be consulted by the Jury, however they have no right to vote.

### 4.2.2 Role of the Jury

The role of the race jury is to:

- take decisions concerning any issues for which the ISMF "Sporting Rules & Regulations" and "Rules for organising ski mountaineering competitions" might seem incomplete or unclear;
- approve solutions proposed in conflict situations or in adverse weather conditions;
- assess claims and decide on their outcome (only the chairman of the jury may register a claim);
- ensure that races and ranking rules are respected
- guarantee sporting fairness;
- attend race meetings.

### 4.2.3 Jury decisions

Decisions are taken by the majority of jury members having the right to vote, with at least three voters. In the event of a draw, the decision taken by the chairman of the jury prevails.

## 4.3 The Start and Finish Areas

---

### 4.3.1. The start area and finish areas

The start area is one of the main points of attention. It contains technical installations necessary for the proper organization and conduct of the race. The start area is of fundamental importance for the management aspects of the ISMF and LOC advertising rights. The start and the finish areas must be at the same location, if possible.

The start and finish areas have restricted access and must be delineated by barriers and / or nets.

They consist of:

1. Nets to separate it from other areas (at least 15m long);
2. An area for controlling DVA (minimum one entrance/line);
3. An area for controlling chips;
4. A start line and two finish lines marked on the ground;
5. Toilets;
6. Equipment control area (for DVA and other compulsory safety equipment, usually post-race). This area for inspecting equipment, must be situated 15 to 30 metres after the finish line. This area is closed off, athletes should have access to a recovery zone immediately after equipment control;
7. Start list controllers (they take note of all numbers – minimum one entrance/line);
8. The starter;
9. People in charge of collecting competitor's personal effects at the start and handing them back at the finish;
10. A warm up area;
11. A race number control area;
12. A medical assistance area;
13. System for timing, photo finish and video control;

14. A notice board for displaying provisional results (**including penalties**) as and when competitors come in.

In case of a doping test, a person of the LOC shall escort the racer to the doping control area (the person must be of the same sex as the racer – see special protocol chapter 8).

After the immediate finish area LOC personnel will take charge of handing back competitors personal effects that were left at the start.

The finish area has a compulsory press area with a location for conducting interviews, preferably immediately after the equipment control area and located inside the restricted finish area.

The World Cup/Championship start/finish areas must be set up in coordination with the:

1. ISMF Event Manager;
2. ISMF Technical Delegate;
3. TV Production Team responsible;
4. Implementation team responsible (for sponsorship requirements);

For all World Cup races and Continental/World Championships, the ISMF referee is responsible for the start procedure, including the position of the athletes on the start line and the final countdown.

Any changes to routes must be announced at least 30 minutes before the start. If the start is delayed, announcements must be made every fifteen minutes.

The typical start and finish areas for every race are presented in Appendix 27 and 28. The appendix defines the typical organisation of the start and finish area, with particular attention to the aspects relating to the management of advertising rights, better specified to the next chapter 8.

#### 4.3.2. *Commercial Village*

Commercial village means the area that, during each ISMF competition, will be set up near the finish and starting area of the race track and which is reserved for LOC, destined to host the LOC sponsor stands as well as initiatives organized by LOC and/or ISMF, offices for accredited press and various services intended for athletes (e.g. relaxation point, Internet connection); the Commercial Village is not covered by the TV camera range.

#### 4.3.3. *Race headquarters*

The race headquarters must be clearly indicated. It must be linked by radio to all checkpoints, to the main organisers and rescue teams.

It is at the disposal of the race director, the chairman of the jury and trail director.

#### 4.3.4. *Spectator areas*

Spectator areas should be set up both at the start and the finish but also all along the course where spectators can watch the race. These areas are marked out under the LOC's responsibility. The LOC must ensure the safety of the spectators (rescue teams, radio links, etc.).

#### 4.3.5. *Press areas*

An area reserved for members of the press should be set up inside the finish area. Only people with a press card will be able to access this area.

Organisers are advised to set up a board displaying race partners/sponsors, in front of which interviews may be conducted.

## 4.4 Race Organisation

---

### 4.4.1 *Race registration*

The LOC must offer the following packages:

Standard race registration + meal after the race + gift: maximum 50€ for one race  
**(The ISMF suggests a reduced fee for the Cadets and Juniors)**

Standard race registration + meal after the race+ gift + 2 nights w/ breakfast  
Standard race registration + meal after the race+ gift + 3 nights w/ breakfast

The LOC must offer national teams, a list of accommodation (hotels, apartments, guest houses...) as close as possible to the competition location with negotiated price rates:

- “Normal standard” accommodation with a negotiated price of 50 € maximum including breakfast with private bathroom in room for 2-3 people.
- “Higher standard” accommodation.

Registrations are carried out directly via internet on the ISMF website (ISMF registration access will be supplied to every organiser). Registrations usually close a minimum of 2-3 days before the race.

A special package must also be available to trainers and press.

Full details of who is entitled to register, etc., is in the Sporting Rules & Regulations at point 3.4.

#### 4.4.2 Race bibs

The ISMF/Infront will provide the following bibs for the World Cup and Championships:

- Blue for senior/espoir men\*\*;
- Green for senior/espoir women\*\* and juniors men;
- Yellow for junior women and cadets;
- White for the open race (or half white/half colour).

\*\*Specific mark/distinctive on the bib to identify espoir racers

The size of the bib cannot exceed 16x16 cm on the rucksack, and 13x13cm on the leg for the individual race, vertical race, sprint race, team race, relay race. The bibs must be placed on the rucksack and on the right thigh (see Appendix 12).

The ISMF/Infront team will liaise with the LOC concerning the number series for the categories.

#### **INDIVIDUAL SPRINT AND VERTICAL**

A RED number will be assigned to the competitor (senior man and senior woman) who is provisionally leading the World Cup on the day of the competition. The following numbers will be assigned according to the temporary classification of the current specialty World Cup. This applies for World Cup and Continental/World Championships.

1st World Cup = Bib Number 1  
2nd World Cup = Bib Number 2  
3rd World Cup = Bib Number 3  
4th World Cup =.... Etc.

#### **RELAY**

- for relays: for each team competitor:
  - 1<sup>st</sup> relay = X-1, 2<sup>nd</sup> relay = X-2, 3<sup>rd</sup> relay = X-3 and 4<sup>th</sup> relay = X-4.
  - the numbers "X" are assigned according to ranking at the previous race for the same title (for a world championship n° N, competitors numbers are determined by their ranking at the world championship n° N-1)
- If a previous ranking is not available for number assignment in a category, then numbers will be drawn at random.

#### **TEAM RACE**

The number will be assigned according to the temporary overall world cup ranking of the best of the two/three team mates.

When a race is comprised of various stages, an athlete who is the leader of the World Cup whilst also leader of the competition, may wear a bib that indicates the position as competition leader (if there is a bib for this purpose).

The categories will be differentiated from each other through their sport numbers, which will have different numerical series.

#### 4.4.3 Race briefings

On the eve of the competition, the LOC, organises a public meeting chaired by the ISMF Event Manager and with the presence of the ISMF Technical Delegate, the race director and the trail director to which all those participating in the event are invited (competitors, trainers, heads of national selections, LOC members, national federations, etc.). All teams attend the briefing. Competitors should at least be represented by their trainers.

The following information is provided:

1. Presentation of race officials, particularly the jury and ISMF representatives.
2. Weather forecasts and snow conditions: snow quantity and quality, forecast temperatures, wind speed, avalanche risks using the European scale, etc.  
It is advisable that a meteorologist is present in the race (or in direct communication with the race) to predict the weather or snow conditions
3. A course description using visual aids (video-projector), specifying change and danger areas, checkpoints and waypoints, technical features of the course and refreshment points.
4. Equipment specifically required for the competition.
5. Race procedures:
  - the start (competitor's briefing, inspection of avalanche transceivers and safety equipment, warm-up area and procedures, start of the race, etc.);
  - procedure to follow for competitors who do not finish the race;
  - information on medical assistance procedures;
  - cut-off times (if any) and race stoppages;
  - short notice cancellation procedures;
  - finish (equipment inspection);
  - claim procedures.
6. Daily event schedule with times and places: breakfast, public transport to and from the competition, car parks, race starts and finishes, anti-doping controls, team leader and jury meetings, results service with groupings and postings, formal ceremonies (awards and prizes), press conferences and other meetings, meals and closing ceremony (if any).
7. Race services: place to leave and collect clothing, changing rooms, showers, catering facilities, communication services and all other necessary information.
8. Information about good environmental practices to be respected during warm-up and races.

All this information will be displayed on a board before, during and after the race briefing. Another short briefing will also be held just before the start of the race by a member of the LOC.

The LOC reserves the right to change the schedule if necessary, at any time, as long as the changes remain within the bounds defined by race organisation rules and is agreed by the ISMF. It can decide to implement cut-off times at any moment of the race. It reserves the right to change the event for safety reasons.

1. A sample (in power point) of the content of the briefing will be provided by the ISMF to every organisation.
2. Any appeals, by coaches or athletes regarding decisions taken by the jury, will be entrusted to the Court of Arbitration for Sport in Lausanne.
3. It should be noted that there is the possibility of unannounced anti-doping controls. In events lasting several days, this could occur every day (at the finish line). All competitors should be aware that once crossing the finishing line, he/she may be required to undergo a doping control.
4. Every competitor has to be able to present an official ID document or a copy if required - **Passport or National ID card** (this may be held by the coach during the race)
5. If a competitor has to pass an anti-doping test, he/she must behave respectfully towards the delegate, the escort, the doctor, etc.

#### 4.4.4 Radio links

Radio links between the various race areas are compulsory and under the responsibility of the LOC. The LOC must provide radios, for the ISMF Event Manager, the ISMF Technical Delegate and referees.

#### 4.4.5 Race curtailment

Curtailment is the responsibility of the LOC trail director and the race director. The ISMF Event Manager and the ISMF Technical Delegate must be promptly informed.

#### 4.4.6 Event stoppage or cancellation

Races may be cancelled or delayed due to extreme weather conditions, safety concerns or unforeseen technical problems. The decision to cancel or delay a race is taken at the discretion of the ISMF Event Manager after consultation with the technical team – Referees and ISMF Technical Delegate - in conjunction with the race organizers.

The possibility to reschedule a race at a later date is entirely at the discretion of the ISMF. A race will only be considered for rescheduling if it meets certain conditions, the organizers are in full agreement, the new date will not cause problems with the international calendar and is not one of the dates agreed at the ISMF Plenary Assembly for hosting national events and is considered appropriate by ISMF media partners. Even when these conditions are met, rescheduling is not guaranteed.

Prior to athletes arriving at the start area, it may be necessary to reschedule the start time due to above mentioned reasons. The new start time must be provided to all national teams with sufficient warning for the teams not to have set off for the event. The start time may be delayed for up to a maximum of 2 hours after the scheduled time once the athletes are in the start area. The delay is confirmed by the ISMF in discussion with event organizers. A delay is only called when it is presumed that the condition causing the delay is likely to be resolved within the time limit as stated. During the maximum delay of 2 hours, athletes must have access to a warm waiting area, drink, and toilets. Athletes are expected to be able to prepare immediately for the start during the maximum waiting period once they are called. No protests are accepted during the maximum waiting time of 2 hours. If the race does not start within the 2-hour permitted delay time, then the ISMF will officially annul the event.

## 4.5 Results

---

Results are to be produced according to the procedure described in the following document:

- ISMF International Ski Mountaineering Sporting and Ranking Rules.

The LOC must make arrangements so that:

- results (provided by the timing company) can be posted at the finish and in the welcome area;
- posting of results is to be announced;
- the place and time of results posting is stated;
- results must be posted within 15 mins of the first racer crossing the line, or when 10 racers have crossed the line, whichever is first. This is so any claims can be made.

## 4.6 Official ceremonies

---

### 4.6.1 General protocol rules

The LOC of the event is responsible for organising all official ceremonies according to the rules and protocol of the ISMF, under the guidance of the ISMF Event Manager.

The flower ceremony for the top three athletes of each category takes place when the results for the top five of each category are official.

The official awards ceremony is for the top five racers of each category.

On the final day of world cup competitions, the official award ceremony will take place almost immediately after the flower ceremony. The definitive protocol will be defined with the ISMF Sport Department before the event. Organisers should have a covered/indoor location close to the race area where ceremonies can take place in the event of bad weather.

Doping tests take place before all other protocol actions. These may be, in some cases, negotiated with the ISMF Event Manager, the LOC, the NF and the sampling doctors. The official ceremony should be completed by 14.30.

Podiums are compulsory for:

- Cup events;
- Cup finals, right after the podium of the Cup;
- Continental Championships;
- the World Championship;
- the first five individual competitors and the first three teams of each category awarded in all categories;

For the Overall World Cup Cup finals, when all the categories are together, it is recommended that the athletes be called from the 15<sup>th</sup> place (Men) / 8<sup>th</sup> place (Women) onwards for the prize giving.

Precise information with the date, time and attending personalities must be sent to the ISMF Administrative office one month prior to the event. The day of the event, this list must be handed to the ISMF Delegate present. The award ceremonies program must be compulsorily agreed with the ISMF Event Manager.

A basic programme for a typical World Cup event is as follows:

Day1	Day 2	Day 3	Day 4
<p><b>Teams arrival</b></p> <p><b>16:00/19:00</b> information of the teams and map/ski pass distribution (Race Office)</p>	<p><b>Welcome</b></p> <p><b>16:00/17:30</b> registration and bibs/gift distribution (Race Office)</p> <p><b>17:30</b> Authorities speeches and Top 5 (Race 1) presentations</p> <p><b>18:30</b> Briefing Race 1</p>	<p><b>Race 1</b></p> <p><b>09:00 to 12:00</b> Race and Flower Ceremony</p> <p><b>17:30/18:30</b> registration and bibs distribution of Race 2 (Race Office)</p> <p><b>18:30</b> Official prize-giving ceremony of Race 1</p> <p><b>18:45</b> Briefing Race 2</p>	<p><b>Race 2</b></p> <p><b>09:00 to 12:00</b> Race and Flower Ceremony</p> <p><b>13:00/14.30</b> end of the event. Official prize-giving ceremony of Race 2</p>

The award ceremonies are a part of the event. Event means all competitions, plus the official briefing, track reconnaissance, the presentation and award ceremonies, official invitations, press conferences and all others activities connected to the competitions.

The LOC must appoint an interpreter to translate speeches into English for every official event. In the event of a delayed race start, the president of the LOC and the ISMF Event Manager will agree on a new ceremony time.

Results that count towards all the ISMF rankings are awarded first and according to the following category order:

1. Cadet women
2. Cadet men
3. Junior women
4. Junior men
5. Espoir women
6. Espoir men
7. Senior women
8. Senior men

The award-winners are called up according to their finish, in reverse order: 5<sup>th</sup>, 4<sup>th</sup>, 3<sup>rd</sup>, 2<sup>nd</sup> then 1<sup>st</sup>.

The winner is always the last person to receive a prize.

The results must be available to all coaches and all press people directly after the end of the race in digital format.

Prizes are awarded by the highest authority present, under the auspices of the ISMF Event Manager and the president of the LOC. The names of the people awarding prizes should be communicated the day before the event. A typical awards presentation is as follows:

1. First place handed over by the ISMF representative.
2. Second place handed over by the Authority of the host country.
3. Third place handed over by the National Federation that organises the event.
4. Fourth and fifth place may be chosen by the LOC.

The race office must be situated in the same building as the briefing room  
Prize giving ceremonies should take place in the same room where lunch is eaten after the race.

All prize giving ceremonies have to take place indoors (unless prior agreement from the ISMF Sport & Events Delegate and ISMF Event Manager), except for the flower ceremony near the finish area.

Parades are only possible on Continental or World Championships (not allowed at World Cup events). Time is allocated for a brief opening ceremony with speeches and distribution of the top five numbers for both races.

If all athletes are staying in the same town and can reach quickly by foot a common room, dinners and lunches can be organized by the LOC in this room. Otherwise, dinners and lunches (except closing lunch/dinner) for athletes will be in their respective hotels.

Lunch/dinners must be a sit-down meal with more than one serving point. The meal must propose at least:

- Entree: Salad
- Hot meal: pasta or/and rice with white meat (turkey, chicken, veal)
- Dessert: fruits

#### **Flags and national anthems( Championships)**

For the podiums, flag triplets are provided. Flags of each nation must be provided for the parade of delegations and for the opening ceremony. They also must be provided to decorate the sport hall for the closing ceremony.

If possible, one flag per nation can be placed in the hotels where the delegations are accommodated.

Provide only instrumental versions of the national anthems, without lyrics.

#### **Others**

At the World Championships, the organizing committee organises a meal for the officials on Thursday evening. It is a simple meal and a moment for conviviality between the different authorities.

#### **General**

Provide rooms for:

- security commissions;
- ISMF Council meeting;
- other institutional meetings of the ISMF, commissions, etc.

The distribution and consumption of drinks with alcohol at the prize-giving ceremonies and official parties is forbidden.

#### **Schedule for world cup, continental and world championships event**

See Appendix 13 – Schedule for World Cup and World Championships event.

Any change in the following schedule has to be presented to and approved by the ISMF Event Manager during the ISMF preseason forum.

## 4.7. Prize money for World Cup and Championships

---

### 4.7.1 *World Cup and World/Continental Championships prize money*

- Minimum prize money is fixed by ISMF Board (see § 2.4. costs assumed by the LOC).
- Equality in prizes for podiums (male/female) is **COMPULSORY**.
- An Espoir could win two lots of prize money - Senior and Espoir.
- **If the number of participants in one category is too low** (less than 10 competitors classified) **then, only the podium places are awarded prize money.**
- The LOC will pay the prize money directly to the competitors during the prize-giving ceremony.

### 4.7.2. *General Overall World Cup ranking prize-money*

- The following prize-money is paid by the ISMF and awarded to Senior categories only.
- The minimum prize-moneys awarded are decided by the ISMF Council.
- The minimum prize-moneys and the number of awarded athletes will be announced during the season.
- Equality in prize-money for the male and female podiums is compulsory.
- The Overall prize money is awarded at the conclusion of the final world cup race of the season, the top five (male and female) must be presented to receive the award. If a non-top five athlete expected to receive overall prize money is not participating in the last race of the season, then he should inform the ISMF at least 2 days before the start of the event
- The ISMF Event Manager is in charge of these matters.

**The Overall World Cup prize giving for the Junior and Espoir will take place at the last race of the season hosting these categories. An ISMF award of recognition will be given to the top three men and women in each category. The ISMF will call 4<sup>th</sup> and 5<sup>th</sup> to the podium.**

## 5. RACES SPECIFICATIONS

### 5.1 General features of ISMF races

	DESCRIPTION	CATEGORIES	POSITIVE ASCENT	DURATION	TEAM COMPOSITION
SPRINT	a varied, short course with ascent, descent, and a walking part with skis attached to rucksack, which will take place in qualifying phases, quarter-finals, semi-finals and final. Race held by heats of 6 runners from quarter-finals to final. Recognition time:15min	SM/SW		Between 3min-3min30s for the best SM/SW	
		EM/EW			
		JM/JW			
		CM/CW***			
VERTICAL RACE	A single ascent on skis, for individual racers. No part takes place on foot with skis on backpack. Vertical race is possible off-piste, but only along a sheltered track with a minimum width of 2 m. The area after the finish line must be completely flat or with a little bit of downhill, and at least 6m wide.	SM/SW	500 to 700m		
		EM/EW			
		JM			
		JW	400 to 500m		
		CM***			
		CW***			
INDIVIDUAL RACE	Minimum three ascents/descents on mountain slopes. The longest ascent must not exceed 50% of total positive difference in height. Out of the total difference in height (positive + negative): at least 85% must be raced with skis on feet; at the most 5% should be raced on foot (footpaths, forest tracks, etc.); at the most 10% should be technical sections raced carrying skis on the rucksack (ridges, couloirs, etc.).	SM	1600 to 1900m	1,5 to 2 hrs	
		EM			
		SW	1300 to 1500m		
		EW			
		JM	800 to 1000 m		
		JW			
		CM***			
		CW***			
TEAM RACE*	Junior men race on the same track as senior women.	SM	>2100m	3 h max for 1 <sup>st</sup> team	2 competitors**
		SW	>1800m		2 competitors**
RELAY*	Two distinct ascent(s) and descent(s) raced by each member of the relay team, with a foot part in the 2 <sup>nd</sup> ascent. Each relay leg must include two distinct ascents and descents. A part of the second ascent comprises a portion to be climbed on foot with skis strapped on the rucksack. Relay leg is run by each member of the relay team. Each competitor can participate <b>only in ONE relay</b> . (That means that, if a junior competitor participates in a senior relay, he / she cannot participate in the youth relay - idem for senior women). Recognition time: 20min	SM	YOUTH	150 to 180 m	Max 15 min
		SW			
					4 competitors
					3 competitors
					3 competitors: 1CM 1CW or JW 1CM or JW or CW or JM Start: CW or JW starting necessarily in 1 <sup>st</sup> lap

\* Athletes holding valid ISMF licences are not allowed to take part in team races that count towards the ISMF Championships with team members of different nationalities.

\*\*can be 3 competitors on continental cups, world cups, and ISMF series

\*\*\* Cadet categories cannot participate or be ranked on world cup races

## Special features for Sprint race (See Appendix 29)

<b>SPRINT RACE DESCRIPTION (SEE ALSO APPENDIX 29)</b>	
<b>1<sup>st</sup> PART: ON SKIS</b>	Approximately 30 to 60 m of elevation. <ol style="list-style-type: none"> <li>1. After the start, approximately 200 m of moderate slope</li> <li>2. The slope then becomes steeper, but has to be easily skiable (not too steep)</li> <li>3. This part should be clearly wide enough to enable athletes to overtake easily.</li> <li>4. The track route must not be plotted along slopes with a highly angled diagonal gradient across the transverse of the slope– if such a situation is naturally found on the terrain, then it must be modified to create a more regular slope.</li> <li>5. The circuit should be a figure of '8' designed with rombs and athletes can choose the most advantageous route.</li> </ol>
<b>2<sup>nd</sup> PART: ON FOOT</b>	<ul style="list-style-type: none"> <li>• Approximately 20 to 30 m elevation</li> <li>• This part must have <u>at least four parallel tracks</u></li> <li>• The ascent is made with skis attached to the rucksack</li> </ul>
<b>3<sup>rd</sup> PART: ON SKIS</b>	<ul style="list-style-type: none"> <li>• After foot part: approximately 10 m of elevation for senior/espoir women and youth, and 30 m for senior/espoir men. Important: all athletes have a ski part after the foot part.</li> </ul>
<b>4<sup>th</sup> PART: THE DESCENT</b>	<ul style="list-style-type: none"> <li>• The slope should be wide, with an even packed surface</li> <li>• The descent must be fitted out with turns. It is permitted the use of blue and red flags (as used for giant slalom) or other safe and visible elements.</li> <li>• The athlete must pass through each one of the gates</li> </ul>
<b>5<sup>th</sup> PART: THE FINISH</b>	<ul style="list-style-type: none"> <li>• The circuit must finish on a flat area or with a slight ascent, so that competitors must use the skating technique until the finish line.</li> <li>• The last 40 m of the course will be set up with a minimum of three wide lanes of approximately 3m width each.</li> <li>• During this part of the race each athlete should stay in lane. Athletes may go out of lane to overtake, but only if they do not hamper the athlete already using the lane.</li> <li>• The course is a loop: with the finish line very close to the start line.</li> <li>• The race must last between 3min and 3min30sec for the best Senior men and Senior women.</li> </ul>
<b>MANAGEMENT OF THE COURSE</b>	<ul style="list-style-type: none"> <li>• A tent heated (with seats) must be set up close to the start area.</li> <li>• The course should be completely closed off by netting, only athletes and accredited press officials are allowed access.</li> <li>• The start and finish lanes are marked on the ground.</li> <li>• For the competitors, a path must be set up to ease access from the finish area to the start</li> </ul>
<b>CHANGE AREAS</b>	<ul style="list-style-type: none"> <li>• The change areas will be wide and fitted out in order to permit all the 6 competitors to make the changes with ease.</li> </ul>

## 5.2 RACE ORGANISATION

### 5.2.1 Course route and markings

The rules which govern course design and marking are as follows:

- If the minimum temperature on the course is lower than - 20 °C the following may occur:
  - the race is held on a more sheltered course (forest);
  - the departure time is postponed until temperature raise to an acceptable level;
  - the total positive difference in height of the race may be reduced;
  - a fourth COMPULSORY layer for the descent can be imposed.
- 1. No night time races.
- 2. First medical assistance has to arrive to any point of the track as soon as possible.

- Unless there are critical weather conditions or important safety issues, the tracks for individual/team race must be ready in the morning on the day before the race (10h00 maximum) or the eve of the first race during a World Cup event. There should be at least one track, with a few flags to give the main direction;
- For Individual, Vertical and Team races: at least 30% of the race duration must be visible from one or two close points easily accessible by spectators. The original track (A option) should include inside the track for bad weather conditions (B option) and the emergency track (C option). To guarantee the safety during the race, a track with some laps and transit zone is the most recommended option;
- For Sprint and Relay races: 100% of the race duration is strongly recommended to be visible from one point (start/finish area recommended);
- For Vertical races: it is recommended to indicate every 100m of elevation from the start to the arrival with a plastic sign, banner or similar. A blue line on the floor is also recommended;
- It is recommended that wide areas should be placed just before technical portions and that special care should be taken to avoid "traffic jams";
- Slow down racers and mark areas with little snow which might present a risk for competitor safety;
- Make sure that trainers, team managers, press members and spectators cannot place objects along the side of the track (except for rescue teams) and cannot invade the track;
- If skis are to be removed, then several wide, flat areas should be prepared for this purpose supervised by a sufficient number of controllers;
- Platforms must be able to host comfortably minimum 10 racers together during the race. Any platform reached by the racer within the first 30min of the race must host comfortably 30 racers at the same time. They can be organized in three platforms of 10 racers;
- All checkpoints are closed with nets, ropes or flags and must have a wide exit (3 m minimum for Sprint race). They are reserved for the competitors and controllers only. Minimum of two controllers/check point;
- Areas for changing equipment (removing or replacing skins, portion on foot, putting on or removing crampons, Ferrata kit and refreshment area) are announced at the race briefing and are indicated on the course by an official pictogram, with the recommended size of 297 mm x 420 mm DinA3 indicating the action to be carried out will be put in the entrance of every checkpoint (available full size on the ISMF website);

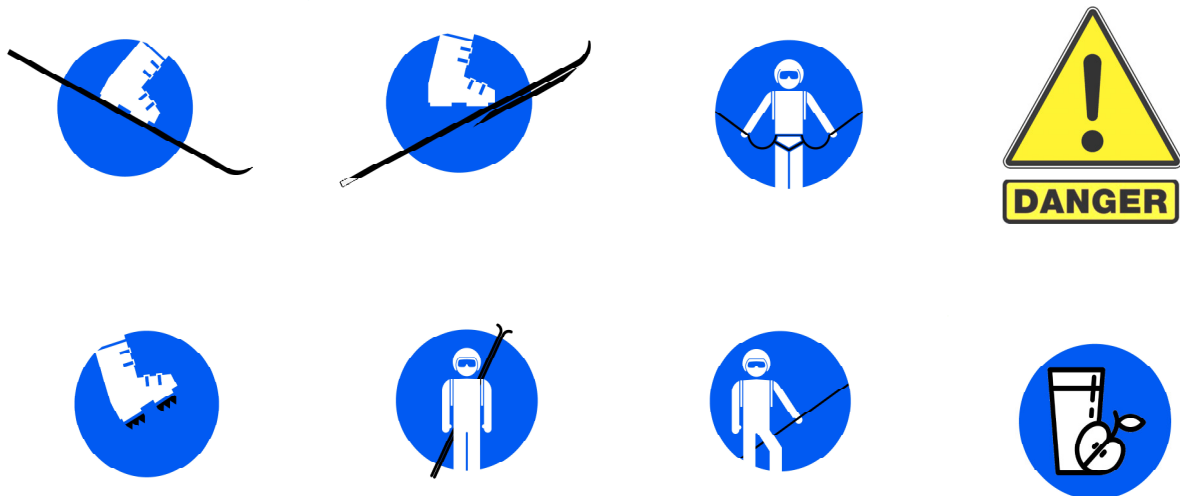

- If the route crosses or follows a marked ski trail, then the portion used by competitors must be separated from that used by others, by means of nets (or any other means making it impossible to cross the course by accident) both during ascents and descents. As far as possible these trails should be closed to the general public for the duration of the competition;
- Junctions for different categories must be located at checkpoints or waypoints where competitors arrive at low speed;
- The tracks in corridors and in ridges will be used for ascents during the second half of the race;
- The parts where the use of the lanyard is necessary must be minimized. On the tracks in a corridor or on a ridge where there is one single lane, overtaking can only take place in the clearly marked zones. It is strongly recommended not to use any of those very technical parts on a world cup or continental/world championship;
- In the event of a risk due to high speed, then LOC tracers should set up chicanes with signs in order to make competitors reduce their speed;
- Organisers are responsible for adapting the speed of the competitors in function of:
  - the ground (forest – narrow trail - risk of dangerous fall - obstacles - ski trail);
  - the quality of the snow (hard, wet or crusty);
  - weather conditions (bad visibility - snow);

They have an obligation to slow the competitors, by using appropriate means (courses drawn in big curves), when a dangerous speed may be reached.

- exceedingly steep slope;
- mass start in descent.

- The route is marked with flags of at least 150 cm<sup>2</sup> (300 cm<sup>2</sup> rigid round fluorescent flags highly recommended)

- Rectangular            15 x 20 cm
- Triangular            15 x 20 cm
- Round                    15 cm of diameter

- Green (fluorescent flags): Moving with on skis with skins on;
- Red (fluorescent flags): Moving on skis without skins;
- Yellow (fluorescent flags): on the parts on foot;
- Junctions or route crossings are marked with arrows showing which direction should be followed by a given category;
- Junctions for different categories must be located at checkpoints or waypoints;
- Large flags must be used during difficult conditions to reinforce marking (minimal height: 1.5m);
- Danger signs mark technically difficult or dangerous areas;
- Specific Danger Flag: to mark specific dangerous elements.



- Respect the environment (see Point 5 – Environmental concerns).

## 5.2.2 The Start

---

### 5.2.2.1 Start Area, Race schedules and Start times

The WC starting/finish area must be compulsory set up in coordination with the:

1. ISMF Event Manager
2. ISMF Technical Delegate
3. TV Production Team responsible
4. Implementation team responsible (for sponsorship requirements)

The starting area is one of the main points of attention and interest of the competition. In the starting area are concentrated technical installations necessary for the proper organization and conduct of the race. The starting area is of fundamental importance for the management aspects of the advertising rights of the ISMF and of the LOC. The start and the finish area must be at the same place.

The starting and the finish areas are restricted and surrounded by barriers and / or nets. They consist of:

1. Nets to separate it from other areas (at least 15m long);
2. An area for controlling DVA (minimum one entrance/line)
3. An area for controlling chips
4. A starting/finish line marked on the ground (as provided in the Sporting Rules & Regulations)
5. Toilets
6. Equipment control area (for DVA and others compulsory safety equipment). This area for inspecting equipment, must be situated 15 to 30 metres after the finish line. This area is closed off and athletes can take time to recover in it. In this area, a controller inspects completely the equipment of the selected competitor.
7. Starting list controllers (they take note of all numbers – minimum one entrance/line)
8. A starter
9. People in charge of collecting competitor's personal effects at the start and handing them back at the finish
10. A warm up area
11. A race number control area
12. A medical assistance area
13. System for photo finish and video control
14. A notice board for displaying provisional results (**including penalties**) as and when competitors come in

Any changes to routes must be announced 30 minutes before the start. If the start is delayed, announcements must be made every fifteen minutes.

A typical start area is presented in [Appendix 27](#).

(The World Cup start area must be set up also in coordination with the ISMF communications team responsible for sponsorship requirements).

Start order and timings will be decided in conjunction between the ISMF Sport Dept and the LOC.

World Cup races, it is strongly recommended to start before 09.00 or after 17.00, except for Sprint races which can be held as a nocturnal event, upon request.

For all World Cup races and Continental/World Championships, the ISMF referee is responsible of all the start procedure, including the position of the athletes on the start line and the final countdown.

### 5.2.2.2 Starting procedure for individual, team, or vertical races:

- The starter positions himself/herself in the starting area in a manner in which all competitors can easily hear his/her announcements.
- Use of a microphone is compulsory. All communications must be made in English.
- The starting area and the trail for 300m after the starting line must be wide.
- Race starts and routes must be planned so that female and youth categories cannot be overtaken by male World Cup categories or by non-World Cup "open" categories, during the race.

- Race starts and routes must be planned so that open racers cannot be overtaken by World Cup categories during the race.
- The start schedule has to be approved on the eve of the race by the ISMF Technical Delegate or by a referee.
- A combined male and female mass start will **ONLY** be allowed if approved by the ISMF appointed Technical Delegate.

Courses must be designed and set up by LOC trail setters. If another race takes place at the same time as an ISMF race:

- The “Open” race for the athletes with no ISMF licence will start at least **3 min** after the ISMF race.
- If this race (open race, course B or C) goes through a shorter course, which could create problems with the ISMF race (traffic jam, risk of collision in descent, etc.), the ISMF race will take place a different day.
- If the race has departures at time intervals, the ISMF race will start at least **2 hours** after the last non-ISMF start.

### 5.2.2.3 Starting procedure for relay races:

- Starting positions must be separated by 1.5m (to be adjusted depending on the terrain);
- If there is not enough room for all competitors on the same line, two or more starting lines (4 m between each line) can be set up for a simultaneous start;
- On uneven ground, the starting line should be positioned in a fair way for all competitors;
- Start order: competitors for the first relay take position on the starting line. Number 1 is positioned in the centre of the track, n° 2 to his/her right, n° 3 to his/her left, and so on;
- Starting marks will be made to the right of the trail
- Competitors must remain in the starting area until relay hand-over.
- If there is not enough room for all competitors on the same line, two or more starting lines (4 m between each line) can be set up for a simultaneous start;
- If there are many ISMF starting lines for different routes or categories, then start order will be given at the race briefing;
- The start area is prepared with a start line and a pre-start line that are 1 m apart.

Race Schedule for Relay:

- Recognition time for Youth teams (20min)
- Youth Race
- Recognition time for Senior Women teams (20min)
- Senior Women Race
- Recognition time for Senior Men teams (20min)
- Senior Men Race

### 5.2.2.4 Starting procedure for sprint races

The “Open” race for the athletes with no ISMF licence will start after the last final of the ISMF race (including the qualifications).

See appendix 30, 31 and 29.

- Lanes are marked for the first 20 m of the course. Competitors must stay in their lane until leaving the designated area.
- For every category, the start will be the inverse order of the classification of the Sprint World Cup ranking, on the day of the competition (N-1 ranking for the first race of the season). The non-classified athletes will start first with a randomly established start time.
- The start area is prepared with a start line and a pre-start line that are 1 m apart.
- A warm pre-start room/tent with chairs for at least 6 racers is recommended to meet the athletes before move to the starts lines.
- In case of false start, athletes are not stopped. The penalty will be directly applied to the athletes after he crosses the finish line. False start penalty applies only if ISMF starting procedure is respected and if there is a camera video on the start line. The penalty applies for the first competitor who commits the false start.
- During the heats sessions the jury may check the start video.
- Heats will start consecutively every 5 minutes.
- Between the end of the qualifications and the beginning of the final phases, there should be 15 minute gap for recovery.
- For the sprint, the jury, in order to make the competition shorter and safer in the case of bad weather conditions, can take the decision to go directly to the final after the qualification stage with the best six places from the qualification. The jury should take this decision before the start of the competition and communicate it to the coaches and athletes, except in the case of sudden reasons that can suggest taking this decision later.

YOUTH RACE SCHEDULE (Cadet & Junior):

**Organizers must obligatory follow the example shown in appendix 31.**



The entire youth race takes place before the senior race.

- 15min Route recognition
- Qualifications: the start time and order will be displayed and cannot be modified.
  1. Cadet Women
  2. Cadet Men
  3. Junior Women
  4. Junior Men
- Finals: Cadets and Juniors go directly from qualifications to finals. The running order is as follows:
  1. Final Cadet Women (6 best times of the qualifications)
  2. Final Cadet Men (6 best times of the qualifications)
  3. Final Junior Women (6 best times of the qualifications)
  4. Final Junior Men (6 best times of the qualifications)
- Semi-finals (6 competitors every semi-final heat) for Cadet & Junior Sprint Races will take place with a minimum of 15 athletes registered in the race. 3 best competitors of every semi-final will go on the final.
- During the qualifications, there will be a 2-minute break between each youth category (female/male Cadet and female/male Junior).
- Flower ceremony for the youth race will take place maximum 10 min maximum after the results of the last final have been posted.
- The route will be open 15 min prior to the senior/espoir (for recognition) directly after the arrival of the last youth final and will be closed 10 minutes before the beginning of qualifications.
- There will be a maximum gap of 30 min between the last youth final and the beginning of senior qualifications.

#### SENIOR/ESPOIR RACE SCHEDULE:

**Organisers must follow the schedule shown in appendix 31.**

- 15min Route recognition.
- Qualifications: The start time and order will be displayed and cannot be modified.
  1. Senior/Espoir Women
  2. Senior/Espoir Men

\*\*If there are 30 or less than 30 senior/Espoir women, the order is reversed and Men start first.

- Quarter Finals:
  - Five quarter finals with 6 competitors.
  - If there are 30 or less than 30 senior/Espoir men, the quarter finals do not take place and the best 12 racers go directly into semi-finals.
  - If there are 30 or less than 30 senior/Espoir women, the quarter finals do not take place and the best 12 racers go directly into semi-finals.
  - There is an in-line start (see placement on the start line), a photo finish or a video control is set up.
  - The first two competitors of each heat, as well as the two "lucky losers" go on to semi-finals.
  - Lucky loser designation: the two best qualification times amongst racers coming in third place during their quarter-finals
- Semi Finals:
  - There is an in-line start (see placement on the start line), a photo finish or a video control is set up.
  - The first three competitors of every semi-final go on to the final.
    1. Semi Final A Women
    2. Semi Final B Women
    3. Semi Final A Men
    4. Semi Final B Men
- Final:

- There is an in-line start (see placement on the start line), a photo finish or a video control is set up.
- The running order is as follows:
  1. Final A Senior/Espoir Women
  2. Final A Senior/Espoir Men

Heat Formation Board: See appendix 30

### 5.2.3 Transition (change) area

---

- The transition (change) areas are all the places where the racers must change their way of progression.
- A transition area is a closed area (with nets, ropes), reserved only for the competitors and the controllers.
- The flags used to delimit the transition area will be of the color of the next section (e.g. yellow if this is before a foot part, red if this is before a descent, etc.).
- A narrow gate (2 m maximum) controls the exit. An image will indicate the operation to be carried out.
- The entrance and the exit gate of the area are clearly marked with a blue line in the snow. Ski tip counts for penalty.
- Controllers must be equipped with radios and be able to communicate with race headquarters.
- Controllers also check safety issues.
- Controllers ensure that ISMF regulations are followed and immediately report any offences committed by competitors to race headquarters.
- Under instruction from race headquarters, the transition area chief must have enough authority to give instructions to competitors (for example: giving instructions to put on an extra layer of clothing, stopping the race under the authority of the race director, etc.).
- The transition area will be positioned so that competitors reduce speed upon arrival.
- At all times, the transition area chief must be able to inform the speaker at the finish on the advancement of the race – competitor racing order – times between racers – etc.

### 5.2.4 Check points (CP)

---

**A check point is an area where the racers bibs are noted. Checkpoints may be located at transition areas.**

Controllers take note when competitors pass through their checkpoint and record their arrival order + times + ranking if the race is neutralized or stopped (example of the sheet to be used in [appendix 34](#)).

### 5.2.5 Refreshment points

---

For Individual and Team Events, the LOC must set up a refreshment point (recommended fresh/warm water/tea, cereal bars, cakes) at the most appropriate location on the track. It must be approved by the Jury (generally at the beginning of an ascent, near the middle of the race). The refreshment point is also to be used by coaches who are not allowed to supply food and beverages at any other location. Garbage or trash bags must be present in the area and near the exit. The recommended length of the area is from 15 to 20 meters.

The refreshment area must be limited by lines (entry/exit) on the ground, and a pictogram at the entry inform the racers is recommended.

See Appendix 33.

### 5.2.6 Relay hand-over zone

---

The relay hand-over zone is an area marked out with a red line for the entry and a blue line for the exit, both of sufficient length (15m meters approx.) and width and situated on a flat or slightly upward sloping area near to the start and finish area.

The race director appoints a person in charge of the relay hand-over zone, and the jury appoints a referee in charge of the relay.

See Appendix 32.

## 5.2.7 The Finish

---

The WC starting/finish area must be compulsory set up in coordination with the:

1. ISMF Event Manager
2. ISMF Technical Delegate
3. TV Production Team responsible
4. Implementation team responsible (for sponsorship requirements)

For all World Cup races and Continental/World Championships, the ISMF referee is responsible of all the start procedure, including the position of the athletes on the start line and the final countdown.

1. A finish line marked on the ground, at least 10 cm wide, preferably situated in a skiable area. Steep downhill slopes must be avoided.
2. A second line, 10 cm wide minimum, will be marked 3 m after the official finish. Upon arriving in the finish area, athletes must pass over the second line before stopping (timings are taking at the first/official finish line).
3. A restricted finish area surrounded by barriers and / or nets.
4. Timing to 1/100 of second to decide between "hand in hand" arrivals and photo finish or video control.
5. A person in charge of taking note of all the numbers of the racers who cross the line (in the arrival order). In the sprint race, during the qualification time this person should note down also the arrival time of the racers to have an extra document in case of technical problems.
6. An area for inspecting equipment, designated "Equipment Control", situated 15 to 30 m after the finish line. This area is closed off and athletes can take time to recover in it. In this area, a controller inspects completely the equipment of the selected competitor.
7. A podium for the first three competitors/teams.
8. A notice board for displaying provisional results (**including penalties**) as and when competitors come in.
9. A medical assistance area.
10. In case of a doping test, a person of the LOC shall escort the racer to the medical control area (the person must be of the same sex as the racer – see special protocol chapter 8)
11. Toilets.
12. A referee from the race jury in charge of finish procedures.
13. Compulsory equipment controllers, with control sheets (see [Appendix 35](#)).
14. People in charge of handing back the competitor's personal effects that were left at the start.
15. A press area with a spot for conducting interviews, near to the equipment control area and located inside the restricted finish area.
16. A person from the LOC in charge of press relations will be present in the finish area to supervise interviews.
17. The placement of the ISMF flags will be decided together with the ISMF Delegate.

- In case of a doping test, a person of the LOC shall escort the racer to the medical control area (the person must be of the same sex as the racer – see special protocol chapter 8).

- In the finish area are compulsory people in charge of handing back the competitor's personal effects left at the start.  
In the finish area, it is also compulsory a press area with spot for conducting interviews, near to the equipment control area and located inside the restricted finish area.

A typical finish area is presented in [Appendix 28](#) of the rules for organising ISMF events.

### 5.2.7.1 The Finish Procedure

- Upon arrival, and under the responsibility of the race jury, the controllers will carry out a complete control of the contents of the competitor's rucksacks and other equipment.
- In case of anti-doping test, an escort authorized by the ISMF shall escort the racer to the medical control area (the person must be of the same sex as the racer).

## 5.3 EQUIPMENT

---

### 5.3.1 Equipment inspection

---

The President of the jury reserves the right to reject any equipment judged to be defective or inadequate.

• **At the start:**

1. individual inspection to control the good working order of avalanche transceivers for all competitors.
2. *Taking note of all the numbers of the racers.*
3. *Control of the chips*

• **At the finish:**

1. Competitor's equipment is inspected (systematic or random inspections according to the instructions issued by the LOC/jury). DVA control after finish line is compulsory for all competitors.
2. ISMF referees will use calibrated scales and weights for equipment checks.

## 6. ENVIRONMENTAL CONCERNS

---

The LOC acknowledges and agrees that respect for the environment is an important consideration in the organization and staging of the Event. The LOC shall carry out its tasks under this agreement in a manner which duly considers the concept of sustainable development complies with the applicable environmental legislation and, whenever and wherever possible, serves to promote the protection of the environment.

The LOC must take all necessary measures to conform with ISMF recommendations (1994), as well as to the 21 directives of the IOC Agenda 21 (1999) and local laws and regulations.

In particular, the LOC should:

- Avoid designing routes that cross areas with sensitive ecosystems.
- Discourage spectators from entering areas with sensitive ecosystems.
- Cause no deforestation or harm to reforestation areas.
- Ecologically sensitive areas must be protected.
- If necessary, restrict areas open to spectators and the media.
- The event should be prepared in collaboration with (and not to the detriment of) any other activities organised in the mountain range.
- Minimise acoustic impact.
- Mechanical means should be minimised (helicopters, snow ploughs, snow scooters, etc.).
- Explosives are not to be used to trigger avalanches outside of ski resorts unless the LOC is authorised to do so
- Provide sufficient amenities for the number of spectators and participants expected: toilets, specific public transport (buses) to and from start and finish areas, information about existing public transport (trains, buses, etc.).
- Rapid removal of race markings at the end of the race.
- Rapid removal of all waste material discarded by spectators and participants.
- Monitoring waste material must continue even once the event is finished. Depending on the location and weather conditions, inspections and extra waste material removal might be necessary during the summer season.
- No sound systems or billboards outside of the start and finish areas.
- Billboards and other means of advertising must be confined to the start and finish areas and to ski resort trails.
- Members of press and spectators must be informed on the importance of environmental protection.
- Protection of ecologically sensitive areas must be ensured by quality trail design and proper route marking.
- Only natural biodegradable products should be used for marking on snow.
- The flora must be protected. Zones that are not or only partially covered by snow must be prepared. If there is insufficient snow coverage, then the event should be cancelled or take place in another location.
- The organisers must ensure that athletes, supporters, spectators and the press remain on or close to the race route.

## 7. RACE SAFETY

---

The LOC is responsible for the provision of medical services to provide maximum assistance to athletes involved in competitions. Such medical services must be available for athletes, officials, spectators and any other person attending, or being affected by, the Competitions (being onsite at least an hour before the start of the event). The LOC must ensure

compliance with the recommendations of the ISMF “Rules for organizing international ski mountaineering competitions” and ISMF “Sporting Rules & Regulations”.

## 7.1 Rescue and emergencies

---

The LOC must provide a rescue service according to directives of the host country including:

- a rescue plan (medical organisation planned for the event, relations with emergency services and hospital admissions);
- agreements involving specialised services;
- agreements with the services of nearby ski resorts.

The LOC must discourage spectators from approaching areas deemed dangerous by the LOC technical staff.

## 7.2 Medical organisation

---

Together with the race doctor (specialized in sports and mountain medicine), the LOC must organise appropriate medical facilities for the competition:

- First-aid stands manned by trained staff at start/finish;
- Medical equipment (with instructions) handed out to LOC members posted on the course (technical and sports committee);
- Facilities for anti-doping tests (see Chapter 10);
- A medical assistance area;
- Relations with the emergency services of the nearest hospital;
- Medical staff must be on the race site at least 1h before the start of the event.

## 7.3 Safety committee

---

This committee operates under the responsibility of the LOC, the NF organising the event and the local authorities of the host country.

The role of this committee involves:

- Approving the different routes;
- Approving the general organisation of the event in terms of safety: protection of competitors, spectators and organisers, etc.;
- Approving planned organisation of rescues and emergencies;
- Deciding if an event should be cancelled or modified for safety reasons, and deciding alternative routes in liaison with the ISMF technical delegate;
- Ensure that slopes on the course showing obvious risks of avalanches are avoided or made secure;
- The safety committee will regularly inform ISMF of any actions taken such as police controls, safety, evacuation plans, etc.

The safety committee is composed of:

- A local authority representative (in Europe this is usually the mayor);
- The LOC president;
- The LOC trail director;
- The head of the LOC rescue team;
- Officials from state rescue services;
- The LOC race director;
- The director of the local ski resort
- The LOC race doctor;
- A delegate from the national federation;
- A national technical delegate.

The safety committee should also invite the president of the jury and the ISMF delegate to attend the meetings as observers.

The minutes of safety committee meetings must be written up, filed by the LOC and sent to the ISMF referees

## 8. MEDIA AND BROADCAST RIGHTS

---

All advertising and commercial markings and supports used at the event shall comply with the technical specifications set forth in the ISMF “Rules for organizing international ski mountaineering competitions”.

The LOC shall respect the rights assigned to the World Cup Title Sponsor by the ISMF, as specified in the contract signed between ISMF / NF and/or LOC. In this contract are set out in detail the arrangements for:

- Assignments of Rights;
- TV exposure of the races;
- TV production and TV Production Assistance with the corresponding obligations for the LOC.

**Media and Broadcast Rights**” or **“Rights”** means the fully exclusive rights granted and assigned to in front to film, record, broadcast, communicate, exhibit and distribute the audio-visual feed of the races and any aspect related thereto (including winners’ proclamations, “medals and flowers” ceremonies or the like) throughout the world, in any language and form (e.g. live, pre-recorded, delayed, as well as highlights and excerpts for the purpose of news access), by means of any and all forms of radio and television, the Internet, wireless and mobile communication systems, audio-visual devices and other on-line or off-line transmissions including, but not limited to, any and all forms of broadcast, transmission and distribution via terrestrial waves, satellite, cable, telephone, wire or wireless networks and any and all analogical or digital media and devices now existing or to be invented in the future. These rights shall include the rights to reproduce, broadcast, communicate, exhibit and otherwise exploit and make the programming of the races available to the public by any means and any kind of free TV, pay and encrypted TV, interactive TV, pay-per-view, video-on-demand, near video-on-demand, web TV, IPTV, non-mobile and/or mobile Internet, and also including, but not limited to, DVB-H, broadband technologies and all wireless technologies aimed at reception through mobile telephones or other mobile devices, and any similar other media now existing or to be invented in the future. These rights shall further include, without limitation, the right to exhibit the races in closed circuit public and private places (e.g. on ships, trains, airplanes, hotels, hospitals, schools, military facilities, cinemas, theatres or the like) and the right to make the recordings and video-grams of the Races available to the public through video tapes, DVDs, CD-ROMs, CDs and any other device or media now existing or to be invented in the future.

With specific reference to the next season, ISMF and/or LOC is/are entitled to publish on its/their official internet website(s) footage of the hosted events, according to the specifications listed in Appendix 14.

## 9. ADVERTISING AND COMMERCIAL RIGHTS

---

The arrangements for the exploitation of Advertising and commercial rights for the events of the World Cup, World Championships and European Championships undertaken under the aegis of the ISMF, are defined in detail in the contract signed between ISMF / NF and / or LOC.

The LOC shall respect the rights assigned to the World Cup Title Sponsor by the ISMF, as specified in the contract signed between ISMF / NF and/or LOC. In this contract are set out in detail the arrangements for:

- Assignments of Advertising and Commercial Rights;
- Materials – facilities – assistance;
- Services.

**“Advertising and Commercial Rights”** means the right to use, exploit and market each, the Advertising Spaces and Commercial Rights relating to the Races of the ISMF World Cup, ISMF World Championship and ISMF European Championship.

**“Advertising Spaces”** means each, the spaces and surfaces available for advertisements and commercial identifications at and around the Sites in accordance with the ISMF regulations, therein including each, the spaces and surfaces available for the placement of panels, banners, athletes’ bibs, competition bibs, flags, signs, logo identifications, TV/data walls and backdrops for interviews, air balloons, stands, tents, inflatable arches and any other advertising space and surface of any kind.

**“Commercial Rights”** means each, the rights and opportunities that may be granted to sponsors, official suppliers and commercial partners of any merchandising category, therein including naming rights, merchandising and promotional activities, marketing supplies, sampling activities, hospitality rights or the like.

## 9.1 Services and consideration on advertising rights

---

The Implementation Team will be responsible for the proper management of the advertising materials of the ISMF and LOC sponsor. The Team shall define the positions of the advertising opportunities of the LOC Local Sponsor which will be implemented at LOC and/or its Local Sponsor exclusive care and costs, in accordance with the instructions contained in the contract between ISMF / NF and/or LOC.

Materials and services provided by the Implementation Team free of charge:

- Inflatable arch start;
- Inflatable arch finish;
- Advertising material of World Cup circuit sponsor for the racing track (banners, flags, inflatables etc.);
- Material of ISMF for the racing tracks (banners, flags etc.);
- Backdrop for prize giving ceremonies (flowers ceremonies directly after the races) and official interviews;
- Tent for equipment control;
- World Cup numbers/bibs;
- Plastic band for the courses (on the tack, on the start/finish line, use for example in the sprint race etc.);
- Photo gallery of the events.

In Appendixes 15 – 21 are shown schematically the subdivision of commercial space available to the ISMF and the LOC. It is noted that in Appendixes 3 to 11 are indicated the subdivision for the starting and finish area. In Appendix 25 is indicated a check list that summarizes some aspects of primary importance regarding chapters 7 and 8.

## 9.2 Intellectual property

---

The official name and logo of the World Cup which is “NAME of PRESENTING SPONSOR Ski Mountaineering World Cup” as well as the name and logo of the ISMF as shown in Appendix 22 are the sole property of ISMF.

The LOC shall have the right and the obligation to use the above names and logos including the title sponsor's name for the purpose of the organization of the Event. This shall include the use of the names and logos by sponsors and suppliers of the Event.

## 9.3 Event Publications

---

The LOC shall reproduce the names and logos set out in Appendix 22 in every communication or promotion related to the Event and the Competitions thereof, such as:

- The official website of the Event;
- Event poster(s);
- Banners or other supports bearing the name of the Event;
- The printed Event Program;
- All publications relating to the Event, including press inserts, press releases, start and result lists and any other official publication of the Event.

Event publications may also bear the names and/or logos of other sponsors and/or suppliers. The organizer shall however procure that the use of the names and logo of the event by a sponsor or supplier does not create the false impression that such sponsor or supplier is a sponsor or supplier of the overall World Cup or the ISMF.

As a general rule, the official name and logo of the World Cup including the name of the title sponsor and the name and logo of ISMF shall appear at the top of the publication, with the other sponsors' and suppliers' names and logos appearing underneath or otherwise separated. See Appendix 22.

All official publications including Competition data must use the lay-outs provided by the ISMF as set forth in the Timing and Data Technical Requirements (Appendix 23 and Appendix 24).

### 9.3.1 Use by Event Sponsors

Subject to clause 8, the LOC shall be entitled to grant the right to use the World Cup name and logo always together with designations specific to the event provided that:

- The World Cup name and logo is used only for promotional and not for licensing and merchandising purposes;
- It always includes the name of the World Cup Title Sponsor and it complies with the graphic specifications provided by the ISMF.

### 9.3.2 *The event programme*

The LOC shall publish a detailed programme of the entire Event and all Competitions as hard copy and on the website of the event.

The Event Program shall contain the necessary content according ISMF “Rules for organizing international ski mountaineering competitions”.

The following content shall be published in the Event Program free of charge at the ISMF request:

- One full color advertising page in a premium location for use by the World Cup Title Sponsor (by ISMF);
- One full color advertising page for use by the World Cup Sponsor (by ISMF);
- One full color advertising page for use by the ISMF;
- One full color advertising page for use by the NF;
- A message to the audience provided by ISMF and NF.

The cover page of the event programme shall bear the official name and logo of the ISMF World Cup as well as the name and logo of the ISMF in a prominent position. The proposed lay-out and content of the program shall be submitted to the ISMF Marketing & Communication Department for prior approval, such approval not to be unreasonably withheld or delayed (Appendix 23 and 24).

## 10 COMMUNICATION – PRESS AND MEDIA

---

The LOC shall provide adequate working facilities and a professional press and media service. The press and media service shall be established and operated in conformance with the instructions of the ISMF Office as well as of the ISMF Marketing & Communication Department. A good ADSL internet connection with WI-FI is compulsory on registration area, hotels and press room.

### 10.1 The LOC Press Officer

---

#### 10.1.1 *The LOC Press Officer*

He/she is appointed by the LOC and the national federation. The LOC is responsible for ensuring the recruitment, the quality of work and the salary of the press officer.

The press officer must:

- Draw up the press kit;
- Write press releases;
- Organise press conferences;
- Greet journalists from all the Media: TV, radio, written press, photographers, etc.;
- Monitor press relations;
- Ensure that race results are communicated to all media
- Ensure that race results are communicated to the national federation;
- Ensure that journalists receive proper accreditations/official passes;
- Ensure that ISMF, national federation and LOC partners are promoted appropriately,
- Work in cooperation with the ISMF press officer and provide him/her with all press releases, images or other material in correct English language.

#### 10.1.2 *Press kit*

The LOC will prepare a press kit that must be sent to ISMF before 1<sup>st</sup> June during the year before the race. The ISMF is responsible for sending this kit to the international press, and the LOC or the NF, to the national and local press. When the ISMF has an official partner, the ISMF/partner is responsible for adding the appropriate information to the press kit.

### *10.1.3 The Press releases by the LOC*

Press releases are prepared jointly by the LOC press officer and/or the national federation and ISMF. At the end of the event, the LOC press officer must provide the ISMF press officer by fax, email or other means, all press releases, images, videos, results and any other information about the competition that might be of interest. Press Releases must be written in correct English and in a good journalistic style and must not reflect bias of the hosting country and its athletes.

All press releases must be communicated on paper with the ISMF letterhead. After the event the LOC must provide ISMF with copies of all press articles and video.

By the close of competition day, organisers must send the following emails (as listed below) to [office@ismf-ski.org](mailto:office@ismf-ski.org) and [web@ismf-ski.org](mailto:web@ismf-ski.org):

- Official results (PDF format) as to be released to the press.
- Excel file with the following data for each competitor (including 2 competitors racing as a team):
- Bib number, Family name, First Name, Date (or year) of Birth, Gender, Nation, Race timing(s)
- (cumulative time if many stages)
- Data Format:
- Bib: only numeric values (no letters)
- Family Name: free
- Name: free
- Date of Birth: yyyy-mm-dd or dd / mm / yyyy
- Gender: M / F
- Nation: IOC Country code
- Time: hh: mm: ss (c)

### *10.1.4 Press conferences*

The LOC organises press conferences to present the event. The ISMF must be informed of these conferences so that they can be prepared jointly. ISMF may delegate one or two officials who will assist at these press conferences.

### *10.1.5 Journalists and photographers*

The LOC assigns official passes to journalists and photographers upon presentation of their press credentials (Appendix 1 and Appendix 2). The LOC will set up a press room with free Internet access (broad band), preferably with a WI-FI connection. The LOC press officer is in charge of greeting journalists and assisting them in their work. The LOC press officer will provide them with provisional results as well as with final rankings at the end of the competition and any other documents available on the race and the competitors.

### *10.1.6 Acknowledgements*

The competition speaker must not fail to mention:

- ISMF;
- The NF;
- ISMF and national federation partners;
- LOC partners.

### *10.1.7 LOC and ISMF guests*

The LOC has to organise a meal for the competitors, officials and guests. The LOC must get in touch with ISMF about inviting international guests.

## 11. THE FIGHT AGAINST DOPING

The ISMF intends to battle against doping via several programs, such as those of the WADA. The ISMF intends to successfully apply a doping control policy through the actions and the will of its **Anti-Doping Commission**. The rules governing the activity of the commission, its guiding principles and the respective punishments are highlighted in the WADA approved document: « **Anti-Doping Regulations of the ISMF**» (**ISMF Anti-Doping Regulations**).

The fight against doping is a top priority of the ISMF together NF; the ISMF has in place a program of controls of all the athletes that may be done throughout the year, not necessary during the competition. The fight against doping is a goal to be pursued together with the LOCs who must contribute to the payment of costs for control (include in services - see § 2.4).

ANTIDOPING	Anti-doping can be carried out <u>at races or outside of races</u>	TYPE OF RACE		
		WORLD CHAMPIONSHIPS	WORLD CUP/ CONTINENTAL CHAMPIONSHIPS	All other ISMF races
		YES	YES	NO

The organisers of the competitions included in the ISMF calendar are thus subjected to the following undertakings:

### 11.1 Doping Control Programme

Organisers of competitions included in the official ISMF calendar must provide a financial contribution to the global ISMF testing program. This program is managed, under the authority of ISMF, through an agreement with an external supplier specialized in Anti-doping control.

The program includes:

- RTP management and whereabouts information follow-up;
- Management and organisation of In, Pre- and Out-of-Competition sample collections;
- The cost of testing (sample collections, anti-doping kits, shipment, analysis by a WADA-accredited laboratory), Doping Control Officers remuneration fees and travel expenses;
- The implementation and follow-up of Biological Passports;
- External supplier administrative costs;
- Athlete Passport Management Unit (APMU) costs.

In addition, for the in-competition tests, the LOCs are requested to appoint a person in charge of anti-doping, to arrange for the necessary location (doping control station) and equipment, as well as for a team of escorts, as described in Art. 8.2 and 8.3 below, and to cover for any related costs (except for the DCOs costs which are already covered in the framework of the ISMF/External supplier agreement). The external supplier is available for any question from the LOC with regards to these requirements, at [antidoping@ismf-ski.org](mailto:antidoping@ismf-ski.org).

### 11.2 Doping Control Station (Reminder of basic obligations)

The location for carrying out doping tests must respect the recommendations and the technical characteristics set out by WADA in its International Standard for Testing in force, available on the WADA website [www.wada-ama.org](http://www.wada-ama.org) and above all show **respect to the athletes** subjected to the tests - see Appendix 26.

#### 11.2.1 Test area

The area must be specific for the tests. It must respect the athletes' privacy and sense of modesty, confidentiality, and gender. These are particularly important when dealing with minors (under 18).

It includes a waiting room (see below), a processing room equipped with a large table and chairs, with an adjacent toilet.

### 11.2.2 *The waiting room/area*

The escorts accompany the identified athletes to the waiting area and wait for the Doping Control Officers (DCOs) to proceed with the sample collection.

This area must:

- Be spacious;
- Have as many chairs as athletes and escorts;
- Be heated;
- Provide drinks for each athlete: individually sealed, non-caffeinated and non-alcoholic beverages, which includes a mix of natural mineral water and soft drinks (e.g. Gatorade, 7-Up, Fanta, Sprite, etc.);
- A storage area for the athletes' equipment, skis, boots, etc. This area must be sheltered and secure.

## 11.3 The staff: the DCOs, the «Chaperones», the person in charge of Anti-Doping from the LOC

---

### 11.3.1 *The DCOs*

The DCOs are appointed and remunerated in the framework of the agreement with the external supplier. They contact the LOC and the ISMF delegate before the competition.

### 11.3.2 *The «Chaperones»*

- a) **It is mandatory that as of the time of their notification for doping control, and until the completion of the doping control procedure, athletes selected for doping control must stay under the chaperone's observation at all times.**

Chaperones who accompany the athletes must be:

- A man for a male athlete to be tested;
- A woman for a female athlete to be tested;
- There must be as many escorts as athletes to be tested;
- **They must be major of age** and, wherever possible, have a good command of English.

- b) Training of the Chaperones.

Training of the chaperones is as stipulated in the WADA standards and guidelines by the rules of the host country's ruling body. In the case of lack of training the DCO in charge, or the ISMF delegate by default, may organise an intensive training course, so as to ensure that the doping tests are carried out under the best possible conditions.

### 11.3.3 *The person in charge of Anti-Doping from the LOC*

- a) He/she is appointed by the organisation.

b) Role:

- Reception of the whole staff: DCOs, delegate, chaperones.
- Ensuring the necessary means to carry out smooth doping control operations.
- Everything must be diligently planned: location, drinks, chairs, offices, etc.

- c) The members of the LOC responsible must display: discretion, efficiency, availability.

The quality of the relationship between the athletes and those others involved, depends upon the good handling by the LOC anti-doping official prior to the tests.

## 11.4 Number of tests and selection of athletes to be tested

---

The number and the nature of tests, as well as the selection of athletes to be tested, is established by the external supplier, in the framework of its agreement with and under the authority of ISMF

## 12 APPENDIX 1: ACCREDITATION PLAN

Category - Function	1	2	3	4	5	6	7	8	9
ISMF Board Member	X	X	X	X	X	X		X	X
ISMF Management Committee Member	X	X	X	X	X	X		X	X
ISMF Honorary Member	X	X	X			X		X	X
ISMF Professional	X	X	X	X	X	X	X	X	X
ISMF Pool	X	X	X	X		X		X	X
ISMF Marketing & Communication	X	X	X	X	X	X		X	X
ISMF World Cup Sponsor	X	X	X	X		X		X	X
ISMF Timing & Data Partner	X	X	X		X	X	X	X	
ISMF Partner and Guest	X	X	X	X		X		X	X
NF Council member / NF President	X	X	X	X		X		X	X
NF/LOC Professional	X	X	X	X		X		X	
NF/LOC Sponsor and Guest	X	X	X	X	X	X		X	X
NF Ski Mountaineering Director/Head Coach	X	X	X	X		X		X	
NF Ski Mountaineering Coach/Trainer	X	X	X	X		X		X	
NF/LOC Team Doctor	X	X	X	X	X	X	X	X	
NF/LOC Medical support / physiotherapist	X	X	X	X	X	X	X	X	
NF/LOC Team Press Attaché	X	X	X	X	X	X		X	
NF/LOC Team Serviceman	X	X	X	X	X	X		X	
Media Host Broadcaster	X	X	X	X	X	X		*	
Media TV/Radio editorial staff	X	X	X	X	X	X		*	
Media TV Technician	X	X	X	X	X	X	X	*	
Media Rights Holders (INFRONT)	X	X	X	X	X	X		X	
Media Photographer Agency or single	X	X	X	X	X	X		X	

\* Lift access is provided but no priority lift access

- |          |               |          |                      |
|----------|---------------|----------|----------------------|
| <b>1</b> | Team area     | <b>5</b> | TV/Radio area        |
| <b>2</b> | Industry area | <b>6</b> | Media centre         |
| <b>3</b> | Media area    | <b>7</b> | Timing/Data Area     |
| <b>4</b> | Photo area    | <b>8</b> | Priority Lift access |
|          |               | <b>9</b> | VIP Area             |

## 13 APPENDIX 2: ACCREDITATION PLAN – EXAMPLE OF ACCREDITATION CARD FOR A ISMF WORLD CUP/WORLD CHAMPIONSHIP/CONTINENTAL EVENT

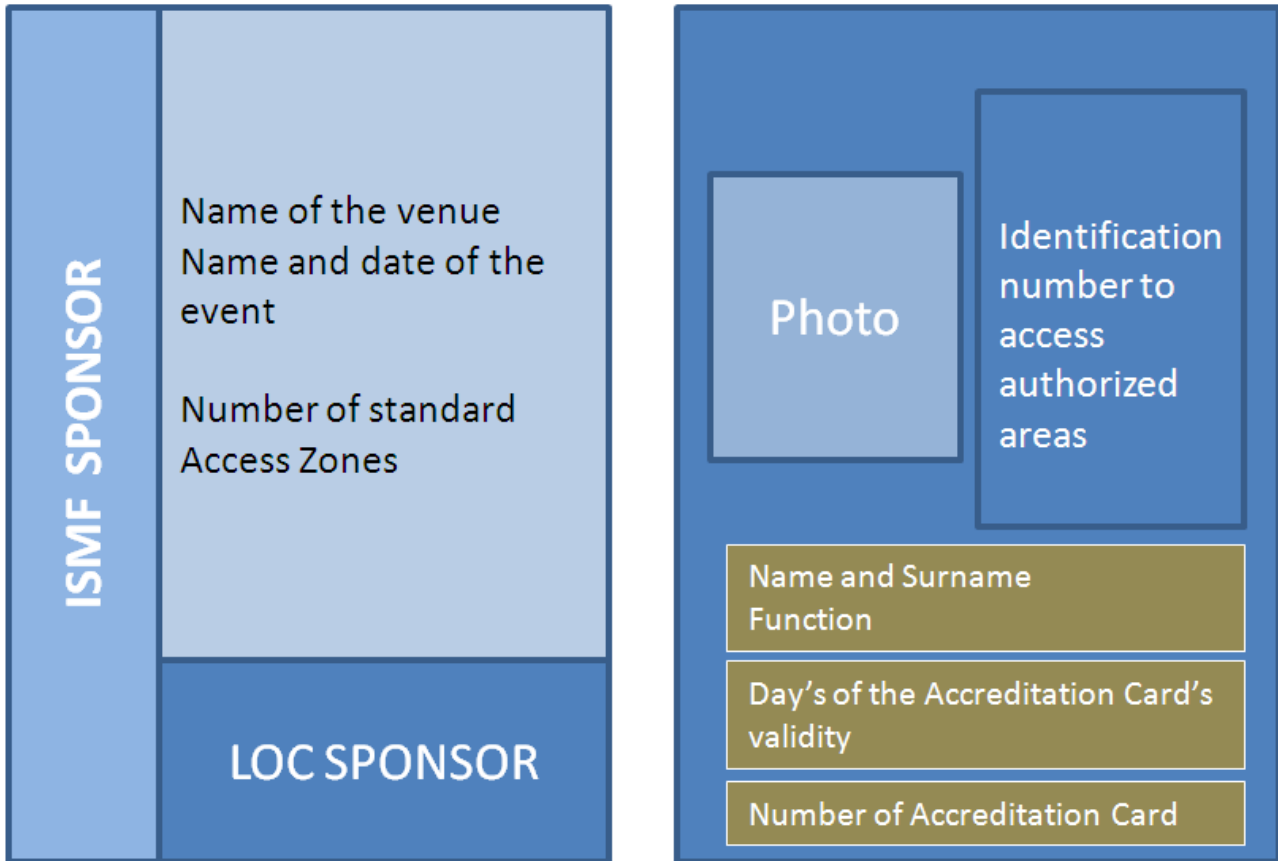

The accreditation card must follow the same requirements as the other publications and promotional materials of the event. The Commercial sponsor of the LOC should not be competitors of ISMF sponsors. The logo of the NF is compulsory.

The accreditation card must be approved by ISMF.

## 14 APPENDIX 3: START AND FINISH AREA – SCHEMATIC EXAMPLE

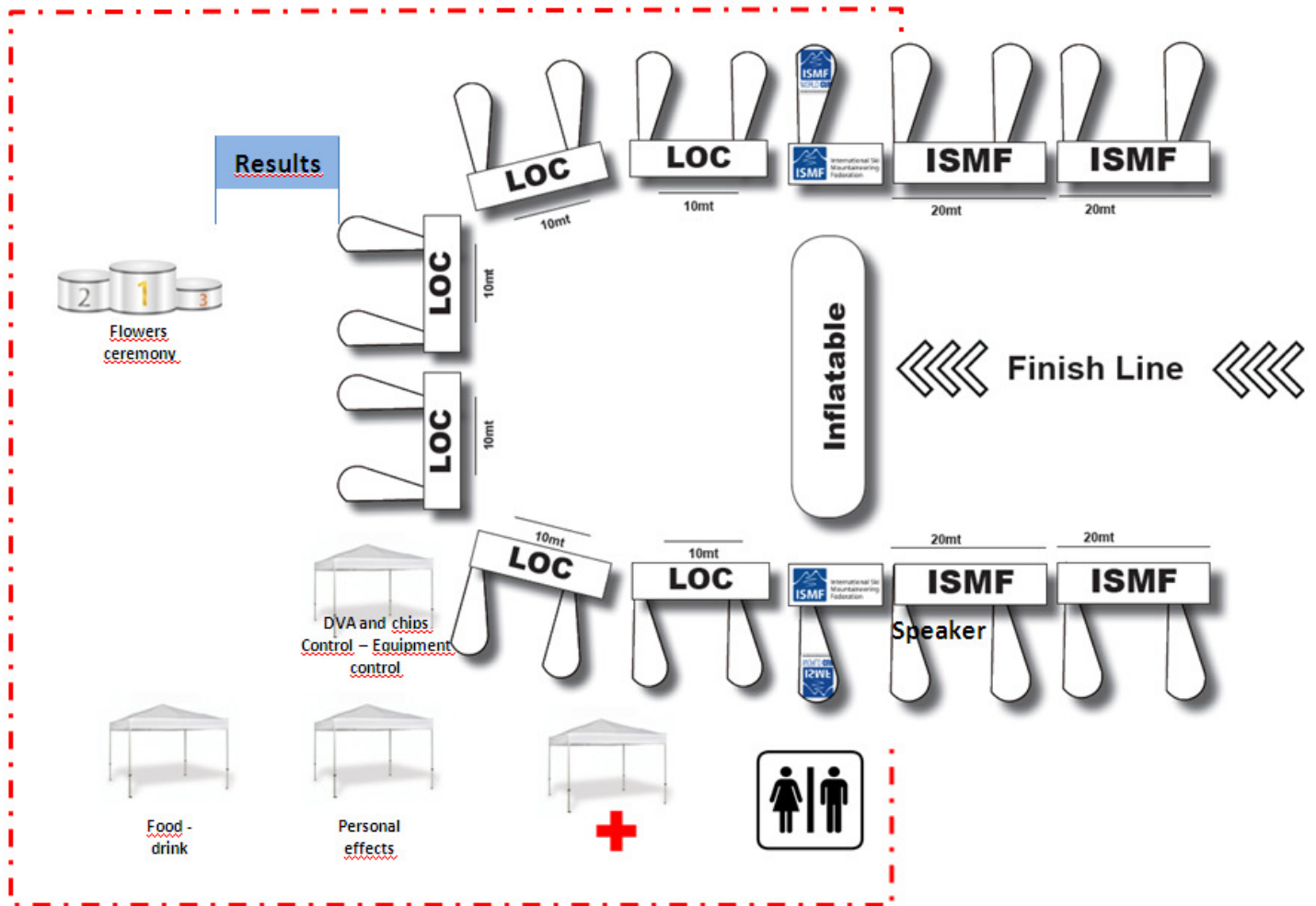

15 APPENDIX 4: START AREA INDIVIDUAL RACE (AND TEAM RACE)

## Individual Race Start

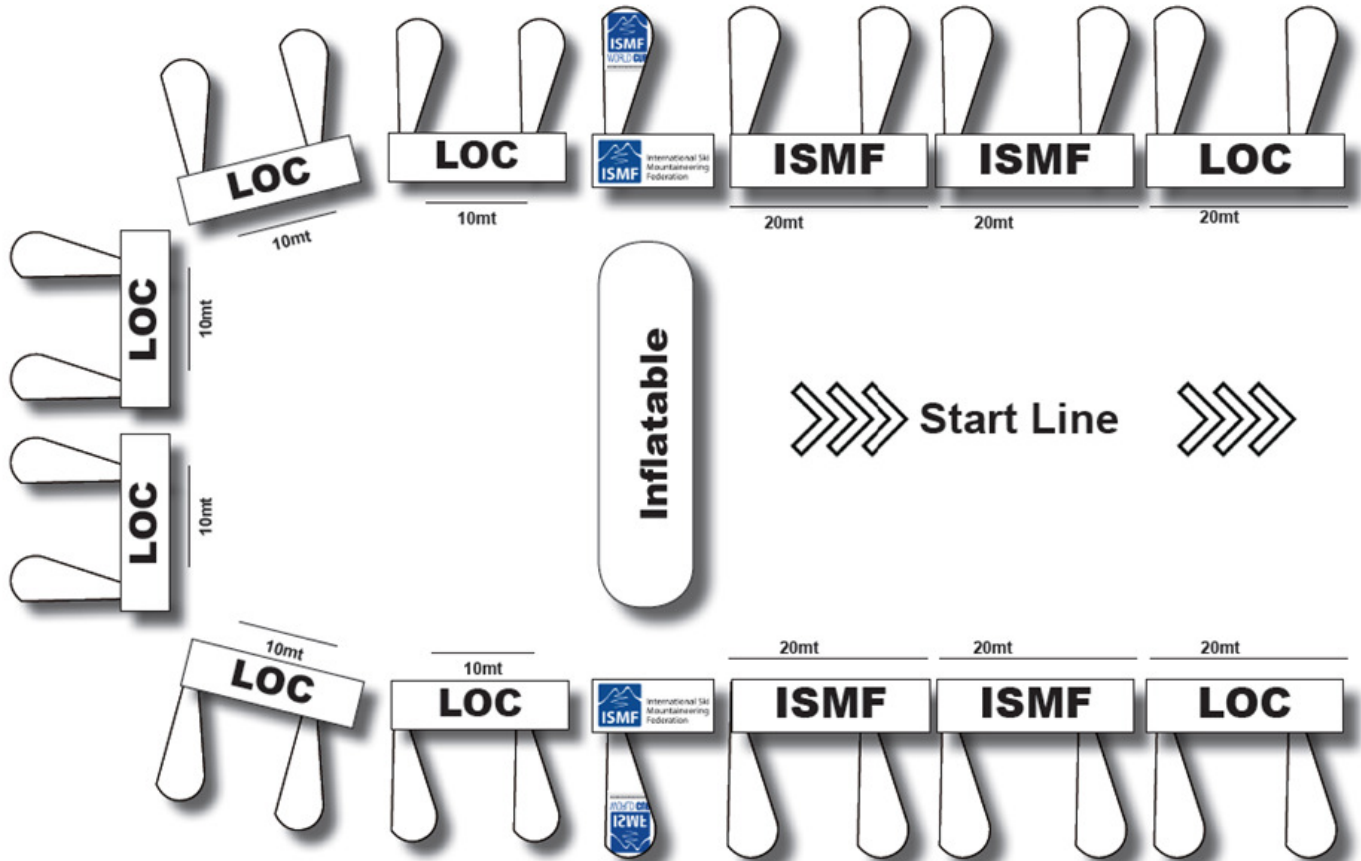

## 16 APPENDIX 5: FINISH AREA INDIVIDUAL RACE (AND TEAM RACE)

### Individual Race Finish

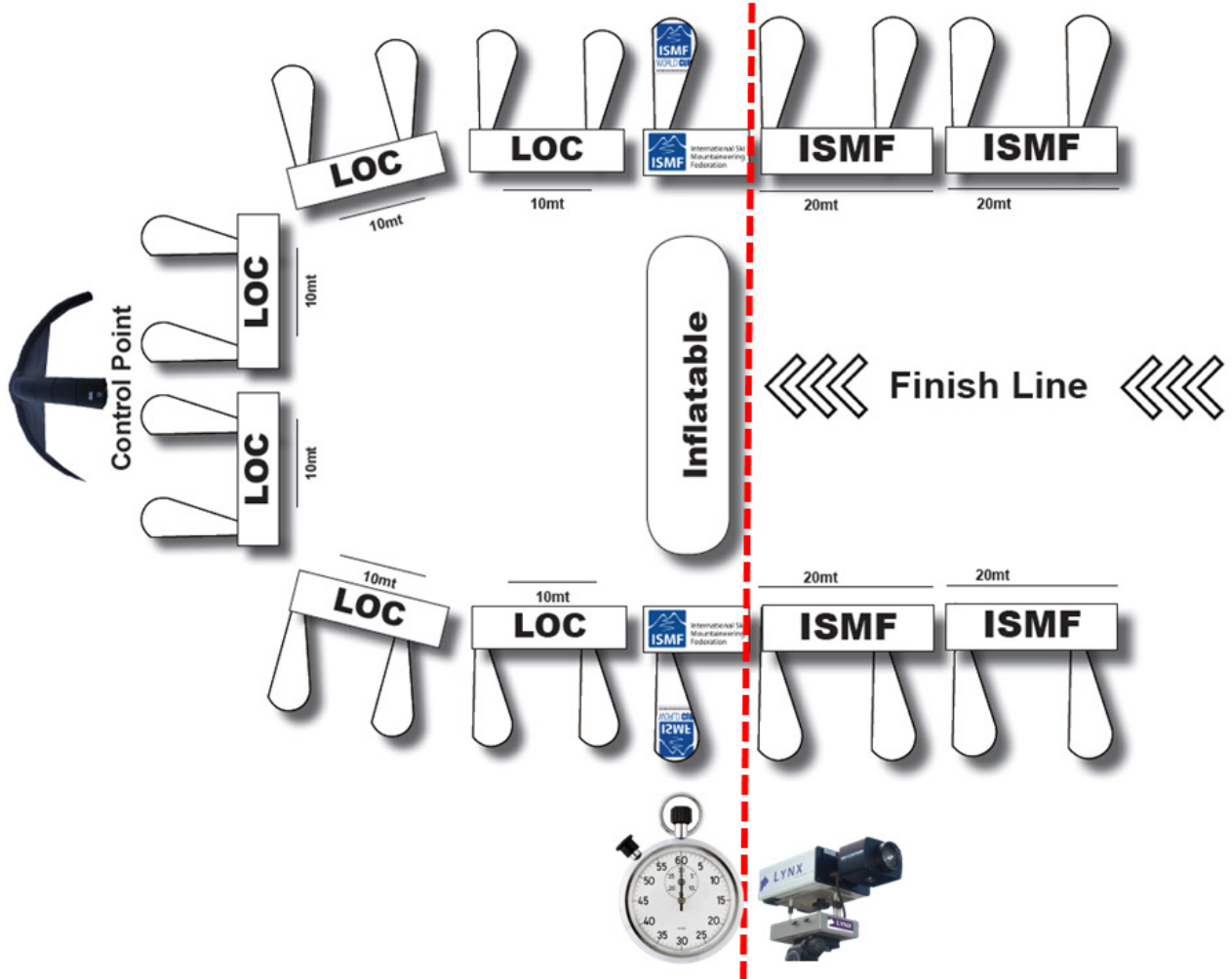

## 17 APPENDIX 6: START AREA VERTICAL RACE

### Vertical Race Start

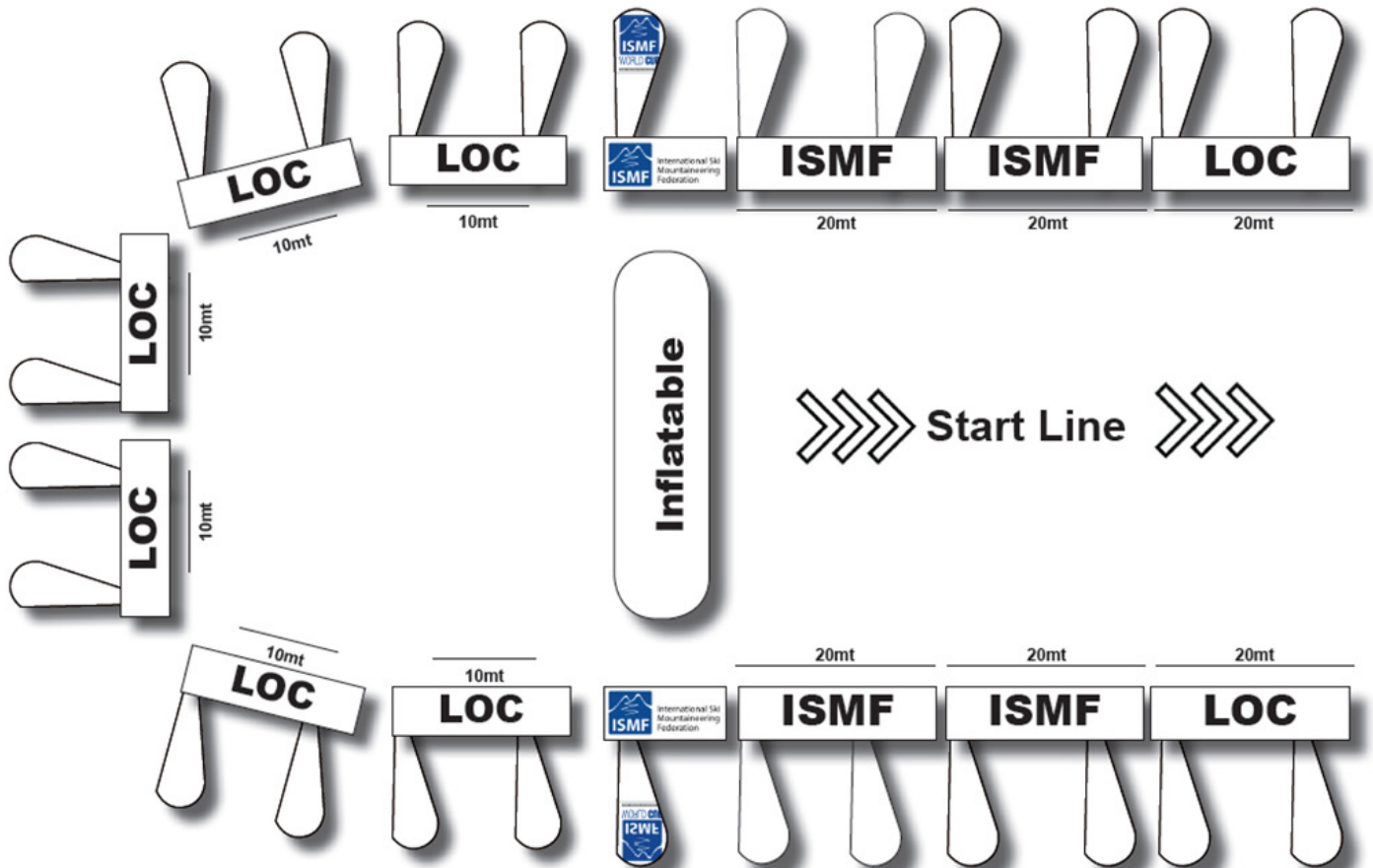

## 18 APPENDIX 7: FINISH AREA VERTICAL RACE

### Vertical Race Finish

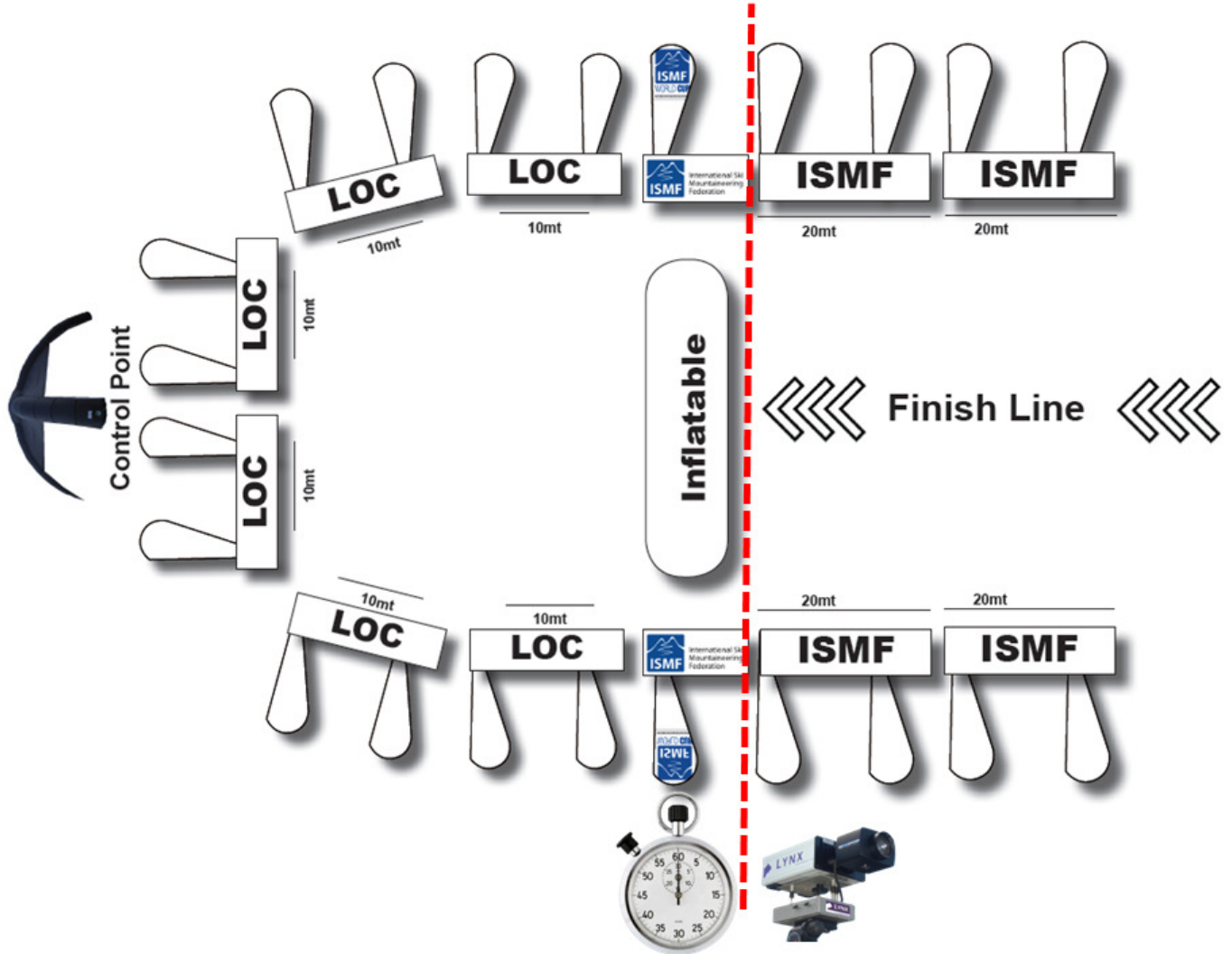

## 19 APPENDIX 8: START AREA SPRINT RACE (AND TEAM RELAY RACE)

### Sprint Race Start

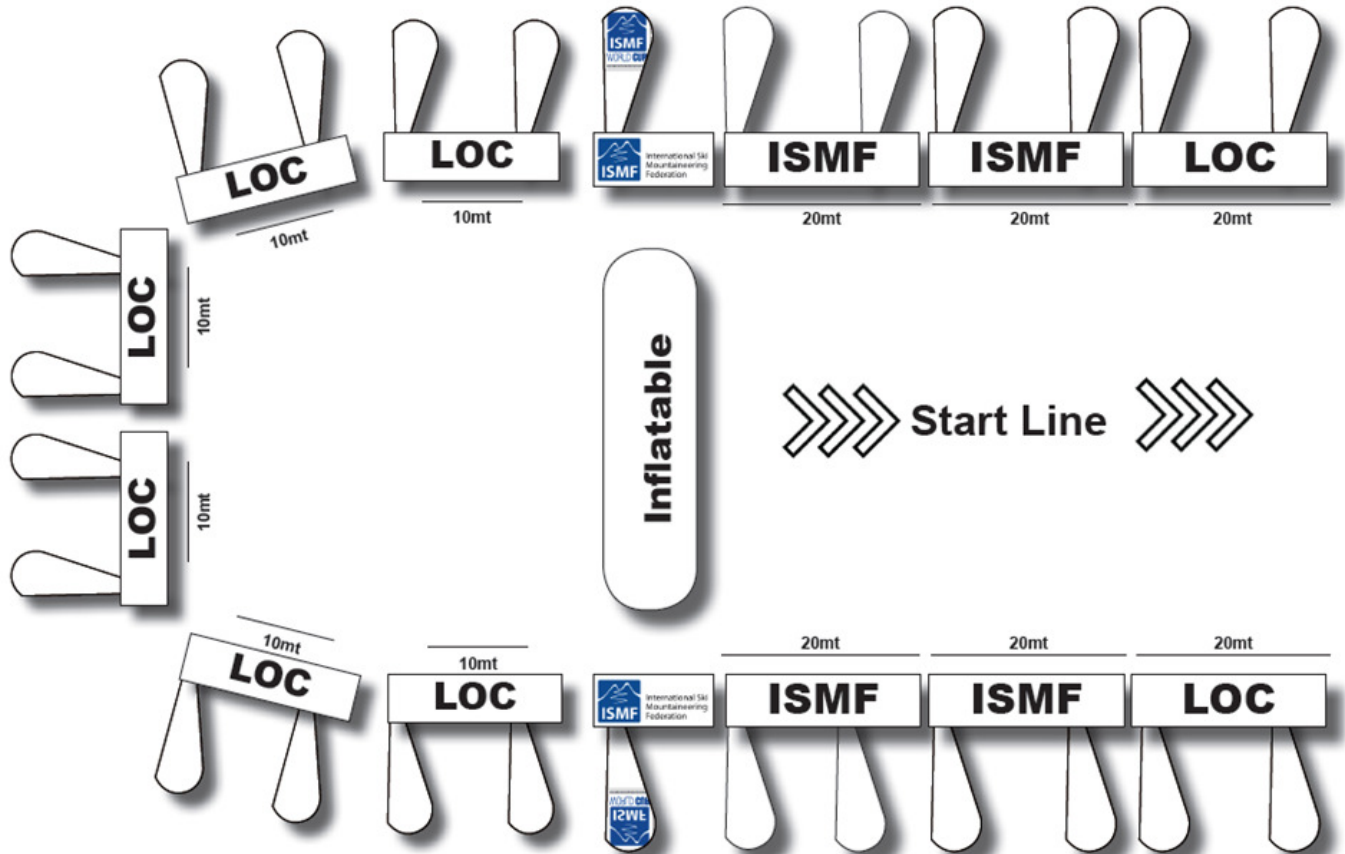

## 20 APPENDIX 9: FINISH AREA SPRINT RACE (AND TEAM RELAY RACE)

### Sprint Race Finish

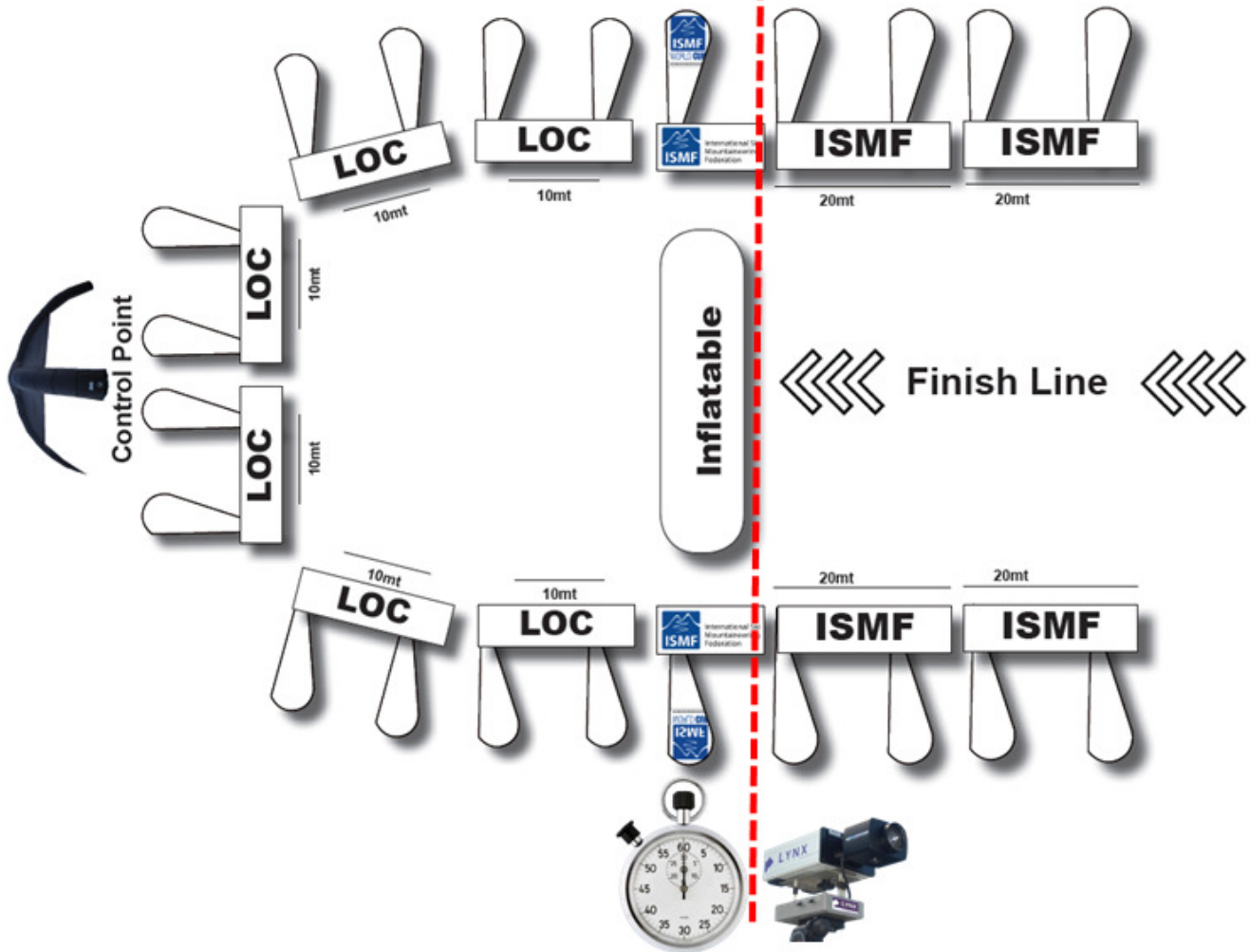

## 21 APPENDIX 10: INFLATABLE ISMF FOR START AND FINISH AREA

# Inflatable Start/Finish

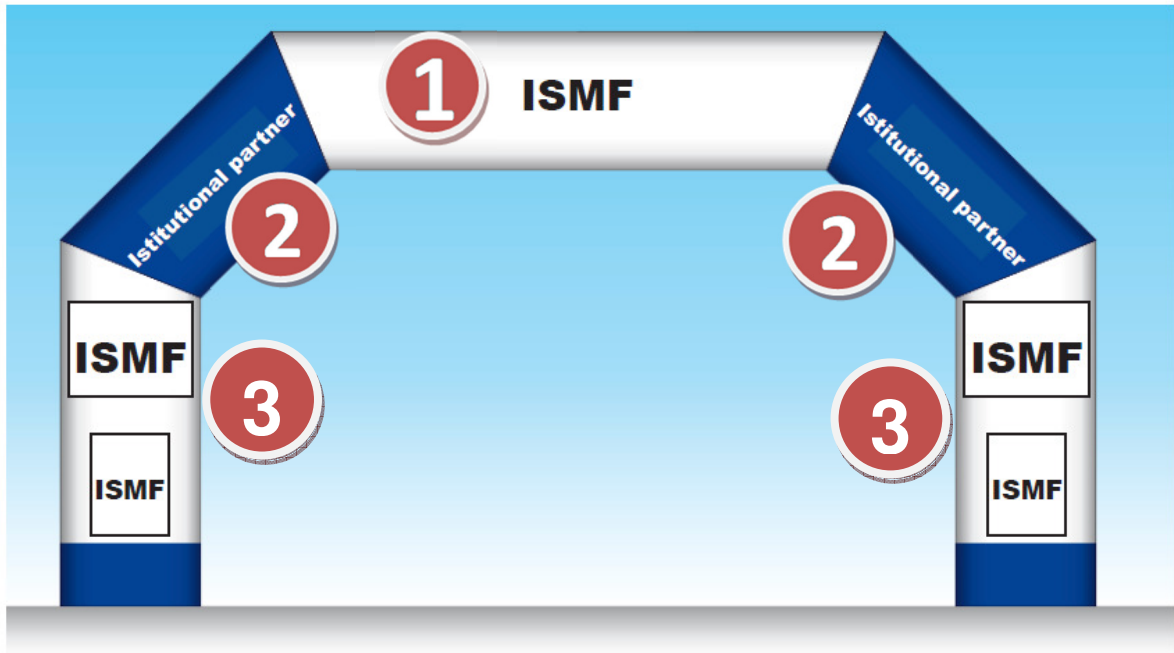

Presenting sponsor of the ISMF World Cup



Space for institutional partners of the LOC (name of the venue, the country, the region, etc.)



Sponsors of the ISMF and official logo ISMF

## 22 APPENDIX 11: BIB

---

# BIB/Starting Number

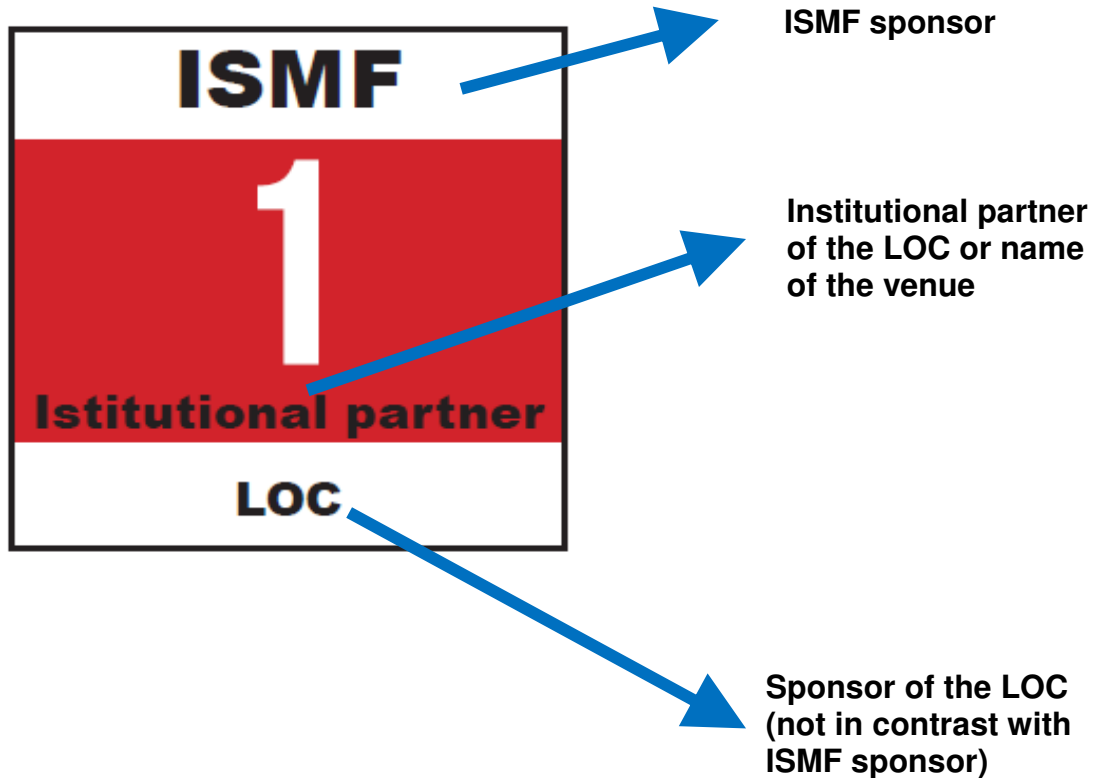

## 23 APPENDIX 12: WORLD CUP AND WORD CHAMPIONSHIPS SCHEDULE

### World Cup event

Day 1	Day 2	Day 3	Day 4
<p><b>Teams arrival</b></p> <p>16:00/19:00 information of the teams and map/ski pass distribution (Race Office)</p>	<p><b>Welcome</b></p> <p>16:00/17:30 registration and bibs/gift distribution (Race Office)</p> <p>17:30 Authorities speeches and Top 5 (Race 1) presentations</p> <p>18:30 Briefing Race 1</p>	<p><b>Race 1</b></p> <p>09:00 to 12:00 Race and Flower Ceremony</p> <p>17:30/18:30 registration and bibs distribution of Race 2 (Race Office)</p> <p>18:30 Official prize-giving ceremony of Race 1</p> <p>18:45 Briefing Race 2</p>	<p><b>Race 2</b></p> <p>09:00 to 12:00 Race and Flower Ceremony.</p> <p>13:00/14:30 end of the event. Official prize-giving ceremony of Race 2</p>

### World Championships schedule

Day 0 Welcome (evening)	Day 1 Sprint – all categories M and W	Day 2 Vertical Race – Senior and Espoir	Day 3 Youth Vertical Race	Day 4 Individual Race – Senior and Espoir	Day 5 Youth Individual Race	Day 6 Team Race – M and W	Day 7 Relay Youth, Senior M and W
	<p>09:00 to 12:00 ➢ Race ➢ Flower ceremony</p>	<p>09:00 to 12:00 ➢ Race ➢ Flower ceremony</p>	<p>09:00 to 12:00 ➢ Race ➢ Flower ceremony</p>	<p>09:00 to 12:00 ➢ Race ➢ Flower ceremony</p>	<p>09:00 to 12:00 ➢ Race ➢ Flower ceremony</p>	<p>09:00 to 12:00 ➢ Race ➢ Flower ceremony</p>	<p>09:00 to 12:00 ➢ Race ➢ Flower ceremony</p>
<p>14:00 to 17:00 ➢ General info and map/skipass distribution ➢ Registration and bibs distribution Day 1 <b>Race Office</b></p> <p>17:30 ➢ Opening Ceremony</p>	<p>16:00 to 18:30 ➢ Registration and bibs distribution Day 2 <b>Race Office</b></p> <p>17:30 ➢ Official prize giving ceremony <b>Sprint race</b> all categories</p>	<p>16:00 to 18:30 ➢ Registration and bibs distribution Day 3 <b>Race Office</b></p>	<p>16:00 to 18:30 ➢ Registration and bibs distribution Day 4 <b>Race Office</b></p> <p>17:30 ➢ Official prize giving ceremony <b>Vertical race</b> all categories</p>	<p>16:00 to 18:30 ➢ Registration and bibs distribution Day 5 <b>Race Office</b></p>	<p>16:00 to 18:30 ➢ Registration and bibs distribution Day 6 <b>Race Office</b></p> <p>17:30 ➢ Official prize giving ceremony <b>Individual race</b> all categories</p>	<p>16:00 to 18:30 ➢ Registration and bibs distribution Day 7 <b>Race Office</b></p> <p>17:30 ➢ Official prize giving ceremony <b>Team race</b></p>	<p>17:30 ➢ Official prize giving ceremony <b>Relay race</b> ➢ Official prize giving ceremony <b>Combined ranking</b> ➢ Official prize giving ceremony <b>Nation ranking</b></p> <p>18:30 ➢ Closing ceremony</p> <p>19:00 ➢ Common dinner</p>
<p>18:30 ➢ Briefing for Day 1</p>	<p>18:30 ➢ Briefing for Day 2</p>	<p>18:30 ➢ Briefing for Day 3</p>	<p>18:30 ➢ Briefing for Day 4</p>	<p>18:30 ➢ Briefing for Day 5</p>	<p>18:30 ➢ Briefing for Day 6</p>	<p>18:30 ➢ Briefing for Day 7</p>	

## 24 APPENDIX 13: FOOTAGE ON OFFICIAL WEB SITE OF THE LOC

---

### **SPECIFICATION TO PUBLISH ON OFFICIAL WEB SITE OF THE LOC OF FOOTAGE OF THE HOSTED EVENT**

With reference to the SEASON, ISMF and/or LOC is/are entitled to publish on its/their official internet website(s) and/or its/their official YouTube channel(s) footage of the hosted events, according to the following specifications:

- a. A maximum of three (3) minutes highlights provided by INFRONT per each event (event means all the races held in one venue during a ski season regardless the number of disciplines) on ISMF's and/or LOC's official website(s) and/or its/their official YouTube channel(s).
- b. Transmission limited to the official ISMF's and LOC's websites and/or official YouTube channels and social media pages (including but not limited to Facebook, Twitter, etc.) accessible on url addresses to be communicated to Infront in advance.
- c. Worldwide transmission, with no need to geo-block.
- d. Not downloadable audio-video material.
- e. For LOCs hosting events every season: transmission until the event of the next season.
- f. For LOCs not hosting events every season: transmission until December 15th. The transmission can be resumed on December 15th of the season in which the LOC will host the event again, until the event date.
- g. Audio-video material not to be licensed, distributed or otherwise shared with any other party, including, but not limited to, sponsors and tourist offices, which will be addressed to INFRONT if interested to obtain footage. Any NF or LOC different from the event host will also be addressed to INFRONT for any footage needs.

## 25 APPENDIX 14: CHANGE AREA INDIVIDUAL RACE (AND TEAM RACE)

### Individual Race

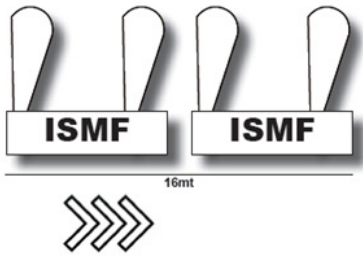

Change Area 1

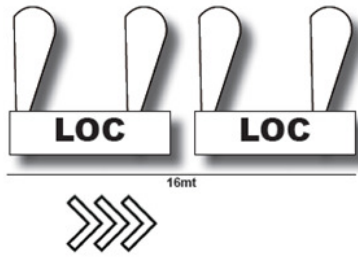

Change Area 2

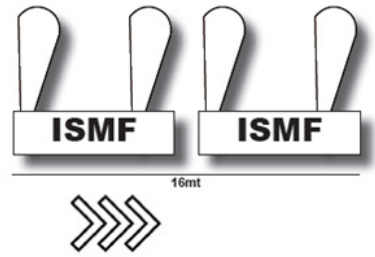

Change Area 3

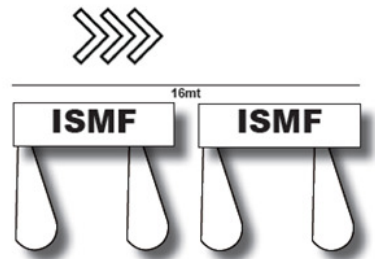
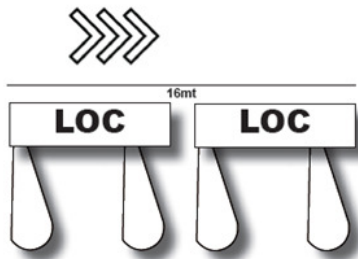
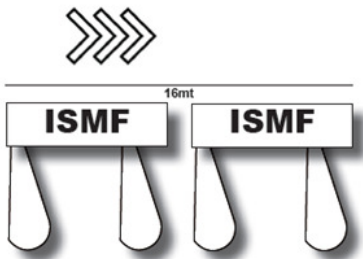

## 26 APPENDIX 15: SCENIC VIEW INDIVIDUAL RACE (AND TEAM RACE)

### Individual Race



**Scenic view 1 (Individual Race)**



**Scenic view 2 (Individual Race)**



**Scenic view3 (Individual Race)**

## 27 APPENDIX 16: INTERMEDIATE AREA VERTICAL RACE

# Vertical Race

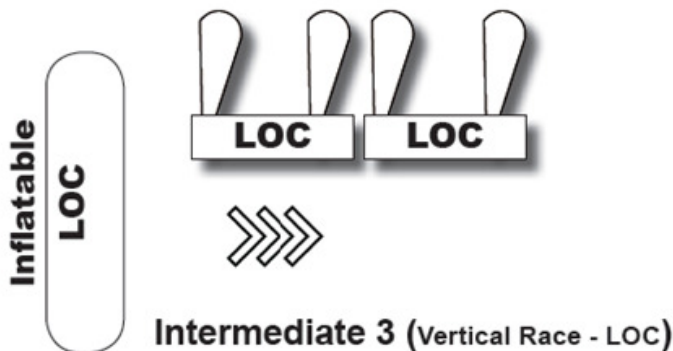
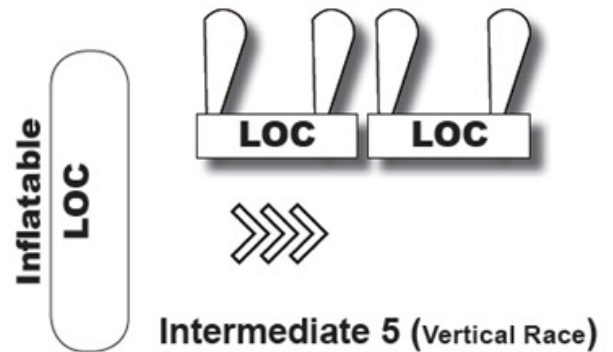
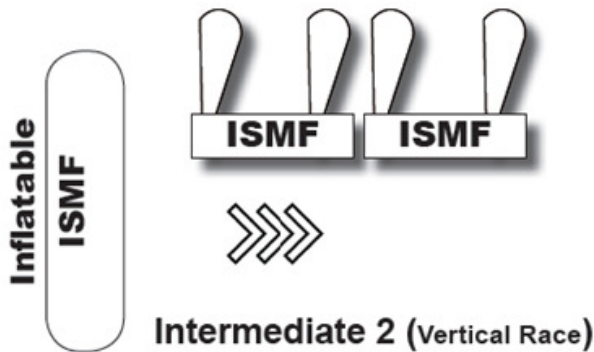
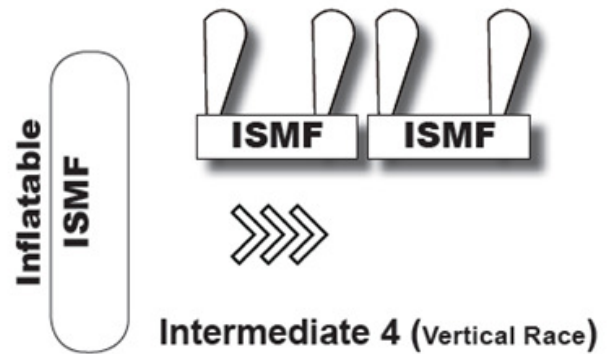
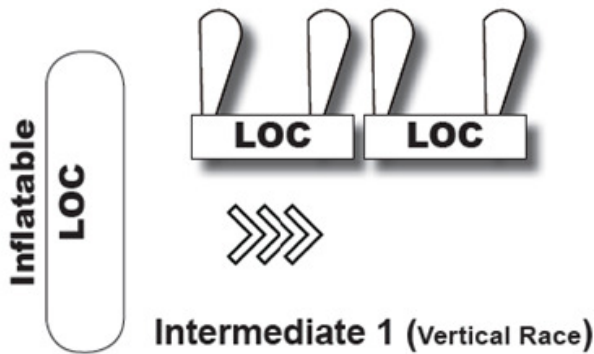

## 28 APPENDIX 17: CHANGE AREA SPRINT RACE (AND TEAM RELAY RACE)

### Sprint Race

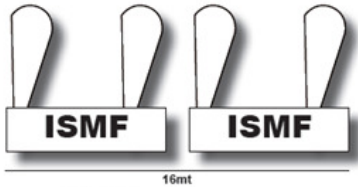

Change Area 1 (Sprint Race)

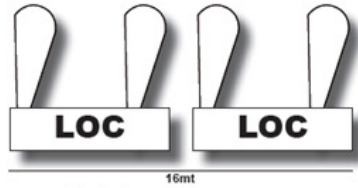
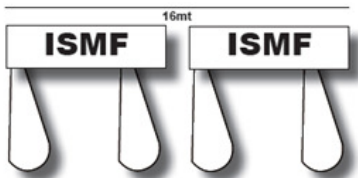

Change Area 2 (Sprint Race)

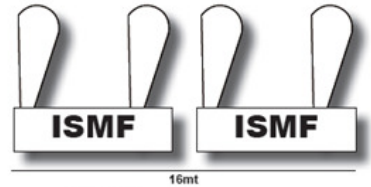
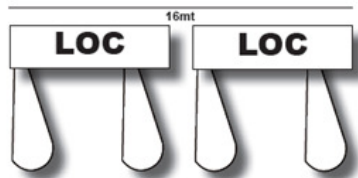

Change Area 3 (Sprint Race)

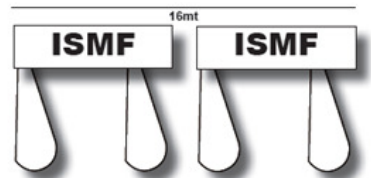

## 29 APPENDIX 18: DOWNHILL SPRINT RACE (AND TEAM RELAY RACE)

---

# Sprint Race

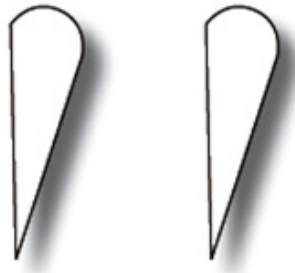

**LOC**

**Downhill (Sprint Race)**



## 30 APPENDIX 19: PART ON SKIS SPRINT RACE (AND TEAM RELAY RACE)

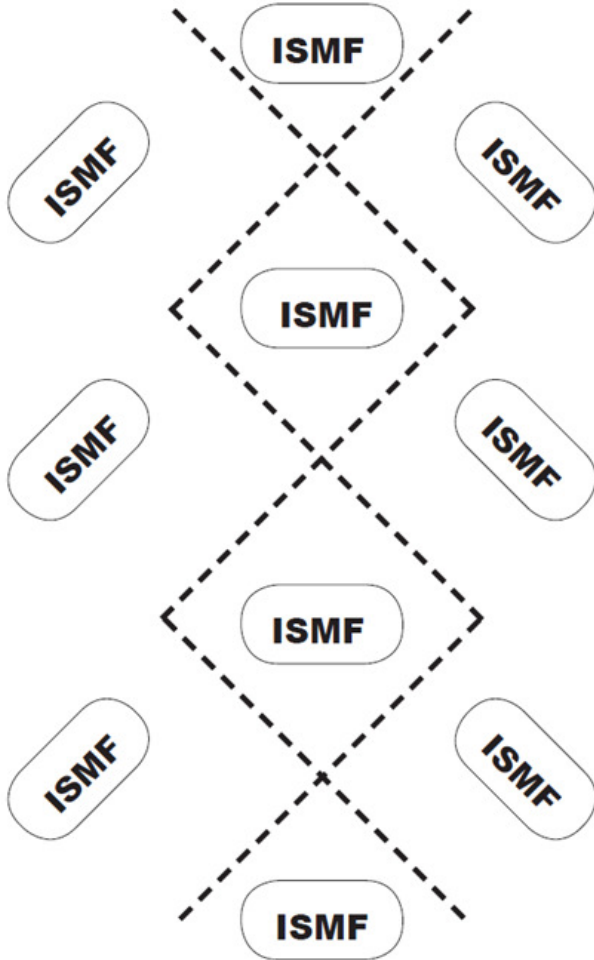

### Sprint Race

#### Part on Skis



## 31 APPENDIX 20: PART ON FOOTS SPRINT RACE (AND TEAM RELAY RACE)

---

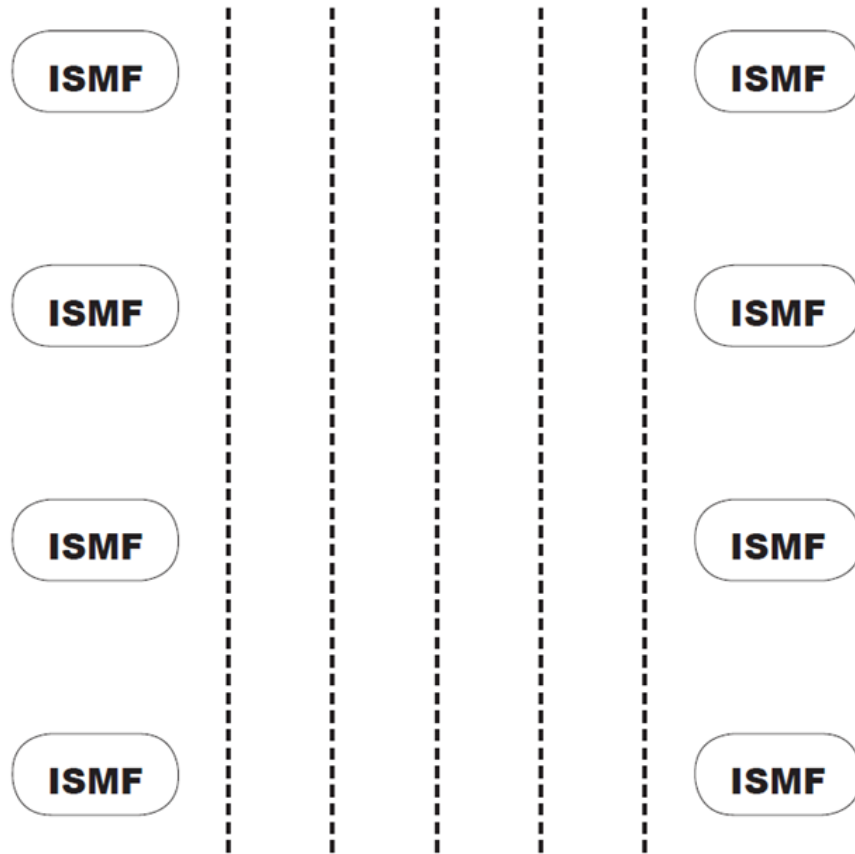

### **Sprint Race**

Part on foots



## 32 APPENDIX 21: LOGOS OF ISMF

---



**Official logo of the  
ISMF Ski Mountaineering World Cup**



**Official logo of the  
sponsors of the  
ISMF Ski Mountaineering World Cup**

The ISMF Office will provide to the LOC all the requirements for the use of the authorized logos

### 33 APPENDIX 22: OFFICIAL PUBLICATION OF THE EVENT



1

Space for the ISMF sponsors

2

Space for institutional and commercial sponsors of the LOC. The commercial sponsor of the LOC should not be competitors of ISMF sponsors. In this space it's compulsory the logo of the NF of the LOC.

All the publications and promotional materials of the event must follow these requirements and must be approved by ISMF.

## 34 APPENDIX 23: OFFICIAL TIMING DATA

---

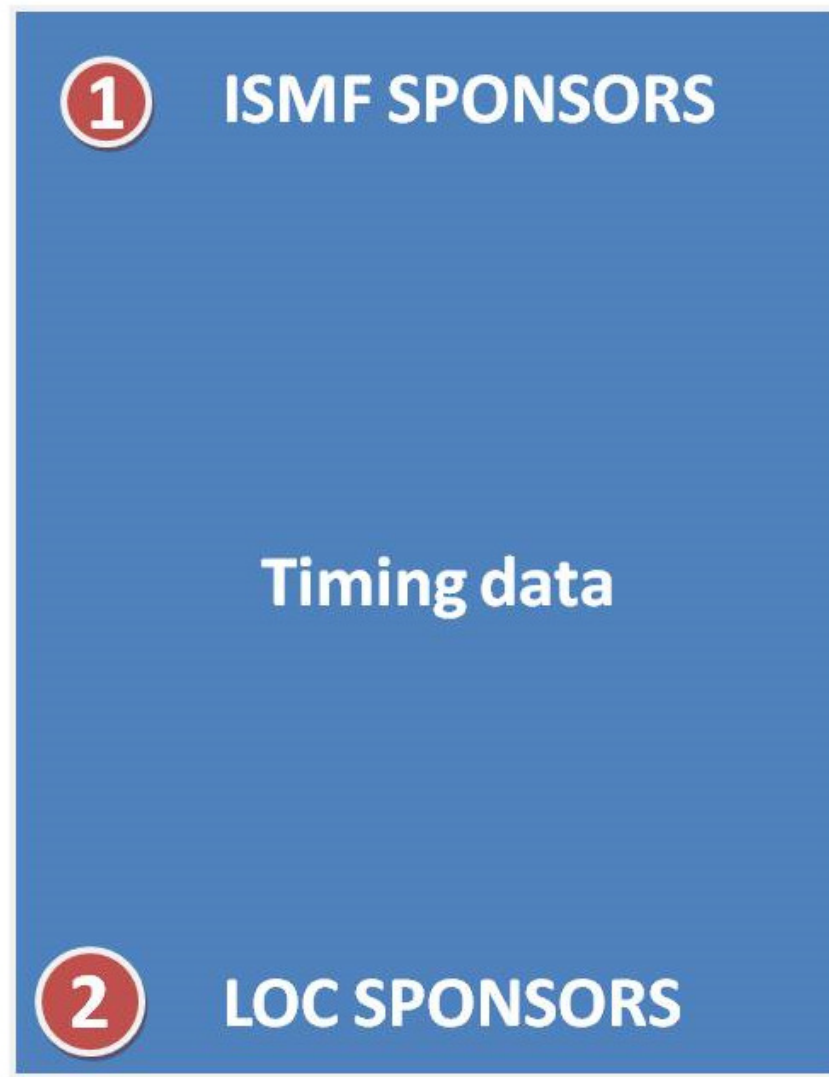

1

Space for the ISMF sponsors. It must appear compulsory in the left side the logo of ISMF and the logo of the NF on the right side. In the center the name of the venue and of the event.

2

Space for institutional and commercial sponsors of the LOC. The commercial sponsor of the LOC should not be competitors of ISMF sponsors.

The official timing data must follow this requirement and must be approved by ISMF.

## 35 APPENDIX 24: CHECK LIST



# ISMF WORLD CUP ORGANISATIONAL CHECK LIST .....(name of the venue/event)..... DATE.....

INFORMATION / ITEM	DEAD LINE	TICK OFF WHEN DONE	NOTES
CONTRACT BETWEEN ISMF/NF and/or LOC			
ISMF INSPECTION / SAFETY REPORT (signed by the ISMF Event Manager)			
RACE BRIEFING			
EVENT PROGRAMME INCLUDING PRIZE GIVING CEREMONY – OFFICIAL CEREMONIES			
DOCUMENT PREPARED BY THE LOC PRIOR TO COMPETITION			
ON – SITE TRANSPORTATION			
START/FINISH AREA LAYOUT WITH RELEVANT ACCESS AREAS			
ANTIDOPING CONTROL DOPING CONTROL STATION ANTIDOPING LOC STAFF			
LIST OF LOC COMPETITION OFFICIALS			
COMMERCIAL VILLAGE			
RACE HEADQUARTER – SPECTATOR AREAS – PRESS AREAS			
ACCREDITATION PLAN			
ON COURSE/INSPECTION LAYOUT			
INTERNET CONNECTION FOR TV AND IMPLEMENTATION TEAM – INTERNET CONNECTION ON FINISH AREA			
ISMF EVENTS PARTICIPATION FEES Antidoping service Time keeping service Awards Ski pass (if the race take place in a ski resort) Travel expenses, financial allowance, accomodation expenses for ISMF officials, TV Team, Implementation Team, Time Keeping Team			
4 RADIOS (JURY - ISMF Event Manager - ISMF Technical Delegate) with microphone			
OC CAMERAS			If any, kindly inform ISMF Office about the specific filming purpose / project (Fan TV, promotional, etc.) and provide them with a dedicated camera sticker as authorized cameras
WEB SITE DECLARATION FORM			Kindly collect them in digital format before approving the personal credentials and send them to Infront by e-mail at the latest when closing the official
OC WEB SITE / ON LINE ACCREDITATION SYSTEM			
OVERALL MEDIA ACCREDITATION LIST			Please send it to the TV Team coordinator immediately after the end of the last race
STICKER FORMS + REMAINING STICKERS			Please collect them for the TV Team coordinator the evening before the last race

## 36 APPENDIX 25: DOPING CONTROL STATION LAYOUT (Example)

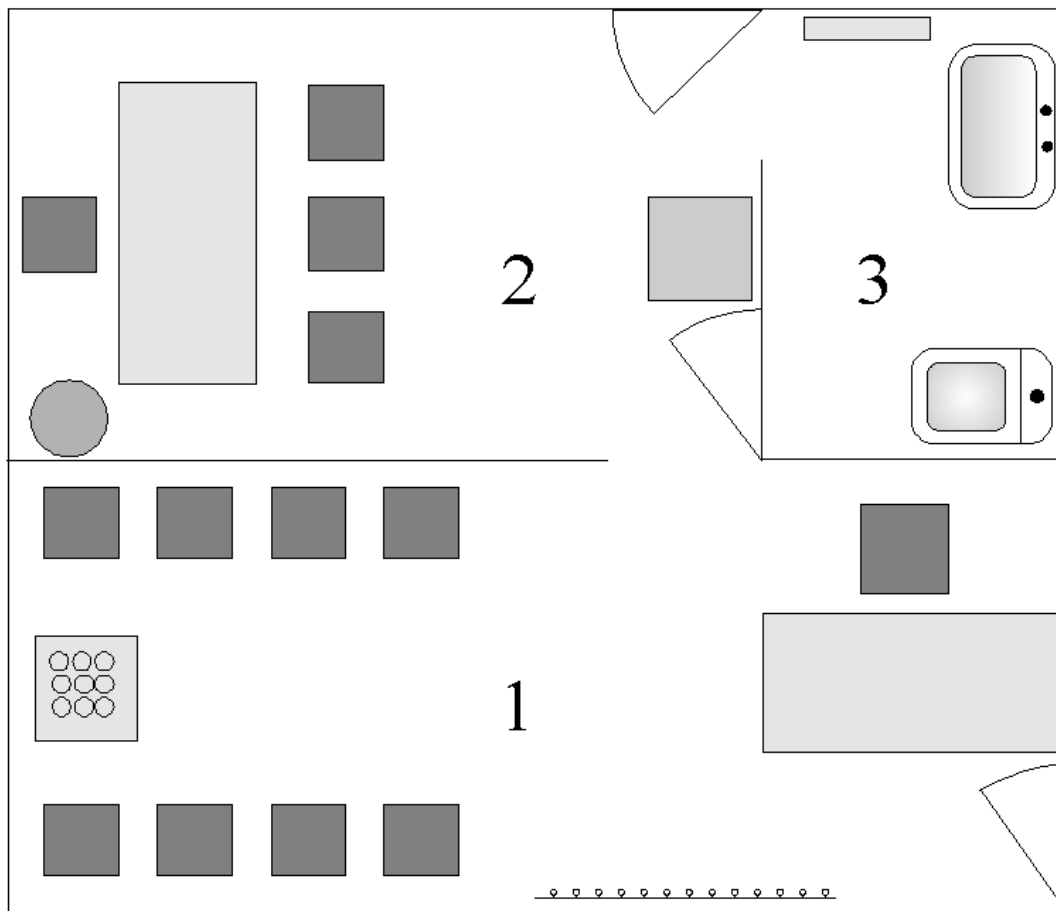

### 1. Waiting Room

- Refrigerator or Cool Box with sealed non-alcoholic drinks,
- Desk, Chairs, Hangers...

### 2. Administration / Processing Room

- Desk, Chairs...
- Waste Bin, Paper Towels, Disposable gloves...
- Refrigerator (Sampling storage) ...
- Telephone or other Communication Device, Scissors, writing material...

### 3. Sampling Room (Toilet)

- Water Closet, Wash Basin,
- Paper Towels, Hygienic Toilet Paper, Hooks



## **37. APPENDIX 26: SPECIAL MOTION FOR ASIA (China and South Korea)**

---

Motion submitted by the Technical Committee because of the specific conditions encountered in ASIA (China and South Korea).

Request for a temporary change in Sporting Rules as described hereafter:

The following only applies to Asia (China and South Korea), as defined according to the following classification: "When a course has been designed on ski trails within a ski resort and if competition organisers consider that no avalanche risk exists, then the following equipment may be excluded from the list of compulsory equipment: avalanche transceiver (DVA), snow shovel and snow probe." The organiser must submit these requests to the ISMF Sport Dept. and must obtain approval when registering the race.



# TECHNICAL APPENDIX

### 38. Appendix 27: Technical Specifications Start Area

Schematic example of the organization of the start lines into the Start Area. The implementation team of ISMF will adapt the start area to the needs and the terrain.

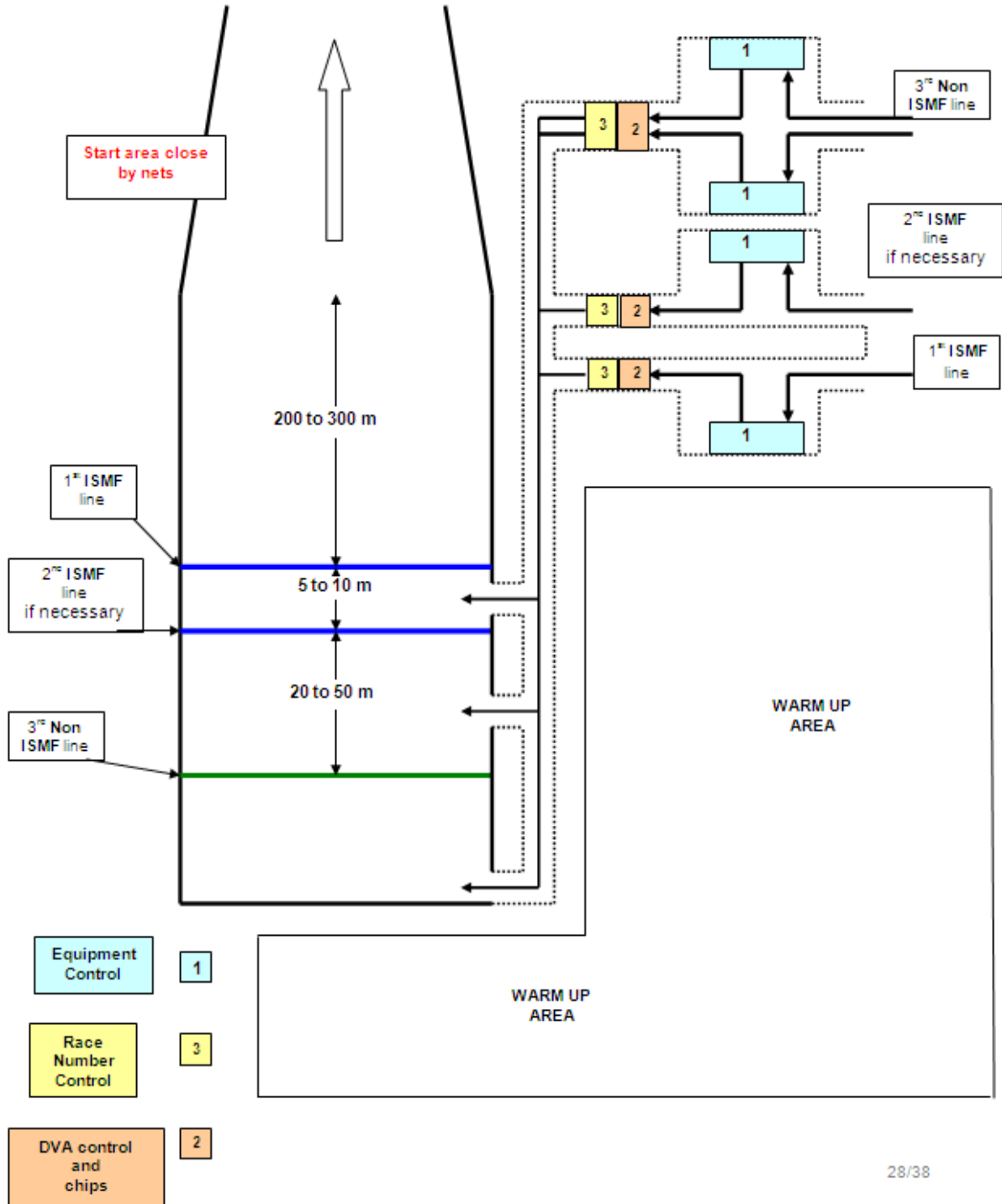

## 39. Appendix 28: Technical Specifications Finish Area

Schematic example of the organization of the start lines into the Finish Area. The implementation team of ISMF will adapt the Finish area to the needs and the terrain.

To INSERT

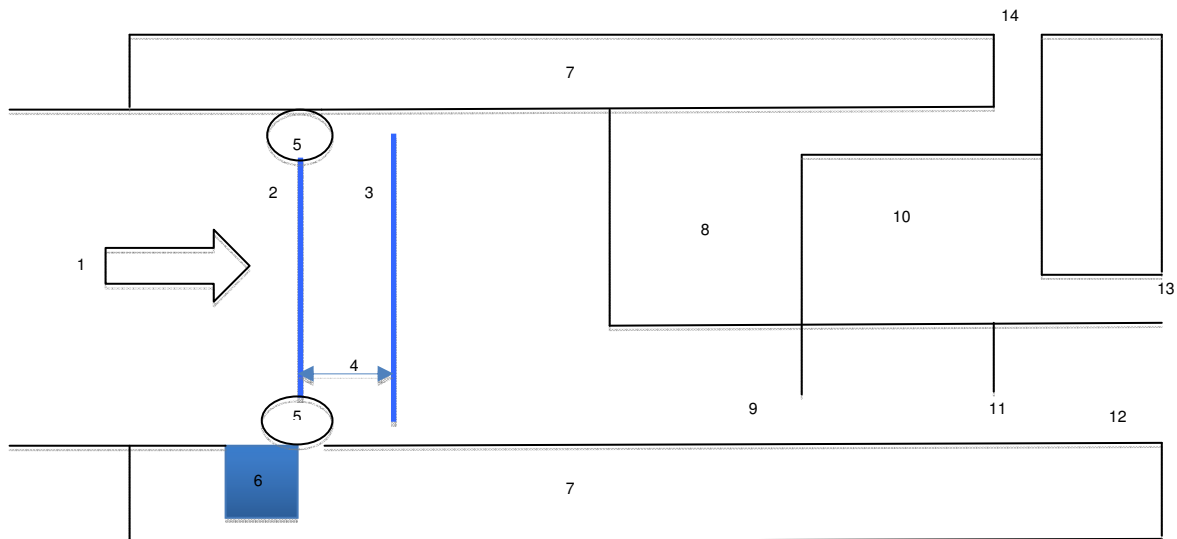

- 1- Athlete/Finishing direction
- 2- Finish Line
- 3- Clear zone line
- 4- Distance between Finish line and Clear zone line: 3m
- 5- Finish Line Arch base – Arches width 8,7 (small) to 13,27 (big)
- 6- Time Keeping tent/area
- 7- Security/Restricted zone (width 2-4m)
- 8- TV and Photo Zone
- 9- Equipment check zone entrance
- 10- Equipment check zone
- 11- Equipment check zone exit
- 12- Finish Area exit
- 13- Equipment check staff entrance
- 14- TV and Photo zone entrance

\*\*Total measures: between 12-22m wide and between 20-30m long.

\*\* The drawing is not to scale.

## 40. Appendix 29: Altimetric profile and design of the sprint

After foot part: approximately 10 m of elevation for senior/espoir women and youth, and 30 m for senior/espoir men. Important: all athletes have a ski part after the foot part.

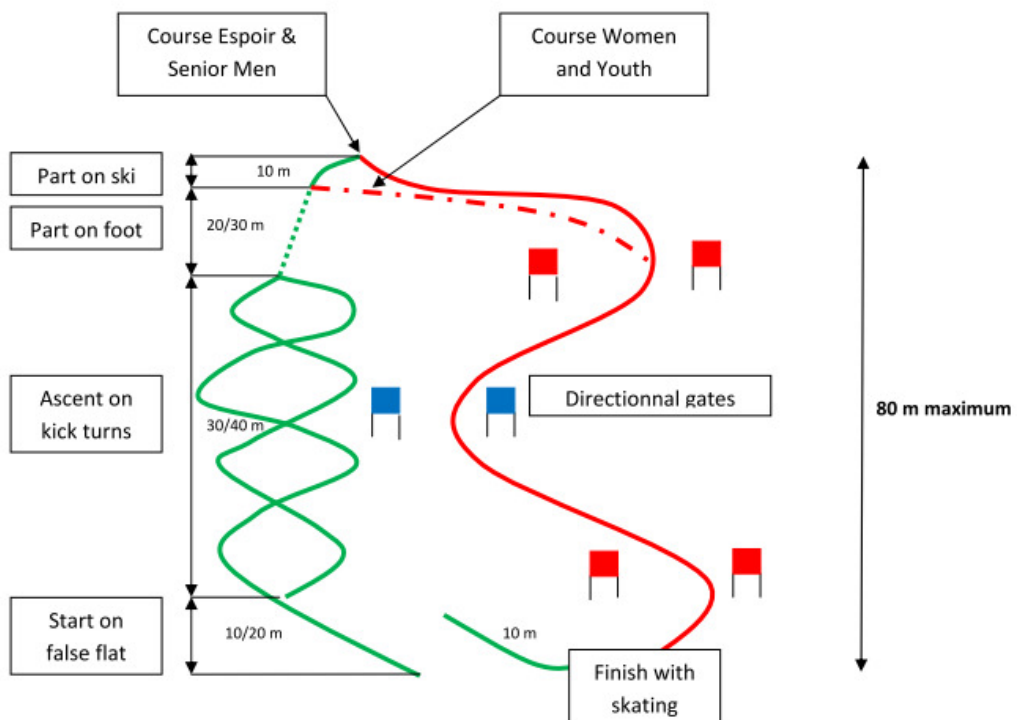
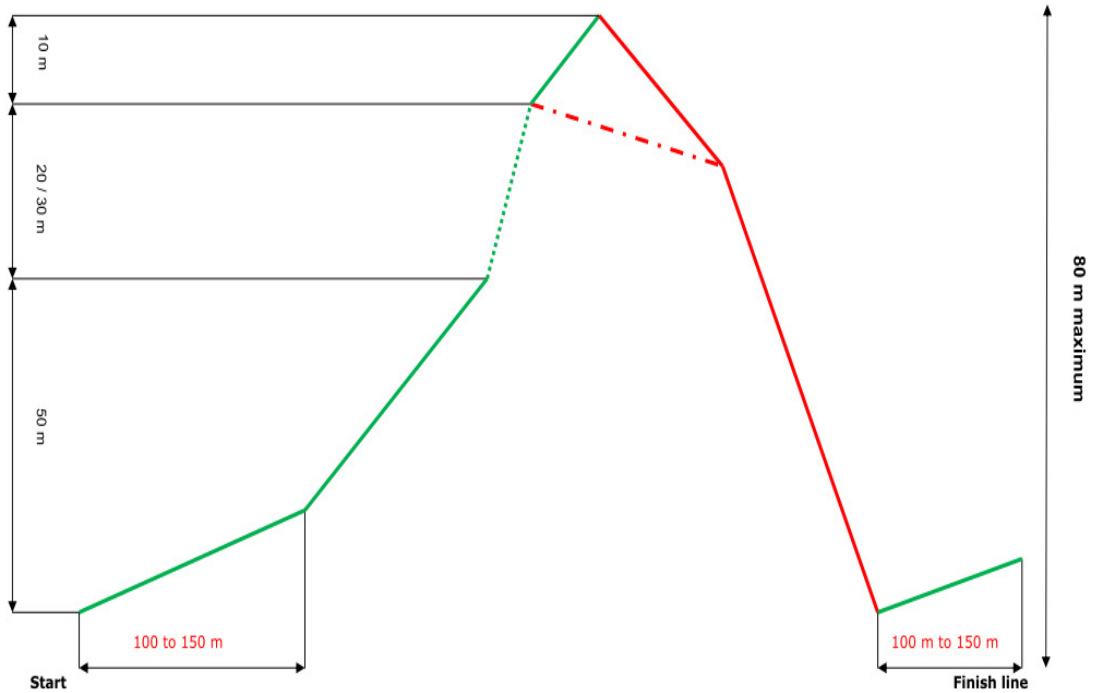

## 41. Appendix 30: Sprint race qualification board

A. If more than 30 athletes in senior men or senior women category

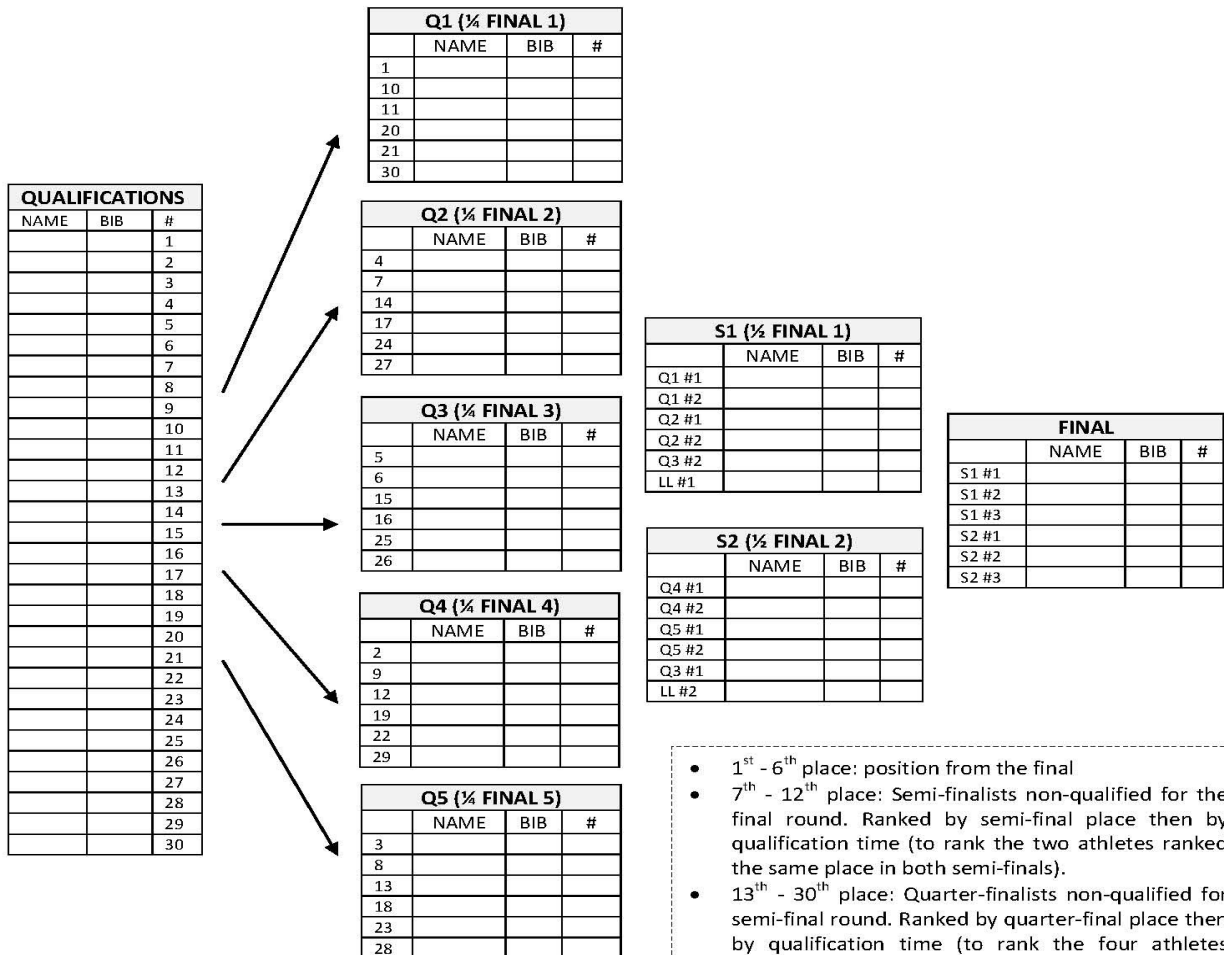

B. If less than 30 athletes in senior men or senior women category

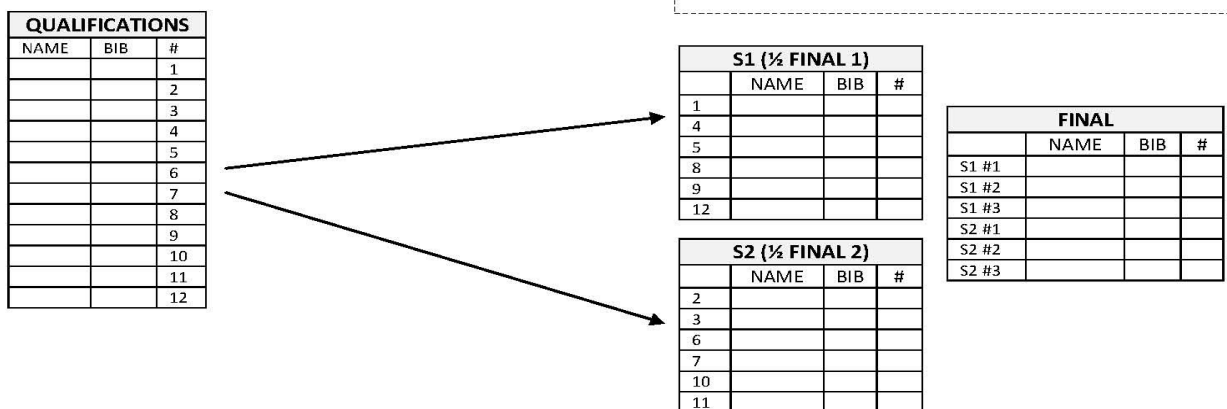

## 42. Appendix 31: Example Sprint Race Schedule (to be adapted with the number of athletes)

**EXAMPLE WORLD CHAMPIONSHIP SPRINT SCHEDULE (based on 2013 Pelvoux world championship participation SM=60 SW=36 EM=16 EW=9 JM=21 JW=7 CM=14 CW=8)**

CADET/JUNIOR QUALIFICATIONS		CADET/JUNIOR FINALS				route open to senior		race closed to senior											
CW	CM	JW	JM	Final CW	Final CM	Final JW	Final JM	Flower ceremony											
50 racers	09:00	09:03	09:08	09:10	09:32	09:37	09:42	09:47	09:55	10:10									
SENIOR/ESPOIR QUALIFICATIONS		SENIOR/ESPOIR FINALS				route open to senior		race closed to senior											
SW	SM	1/4 final SW 1	1/4 final SW 2	1/4 final SW 3	1/4 final SW 4	1/4 final SW 5	1/4 final SM 1	1/4 final SM 2	1/4 final SM 3	1/4 final SM 4	1/4 final SM 5	1/2 final SW 1	1/2 final SW 2	1/2 final SM 1	1/2 final SM 2	Final SW	Final SM	Flower ceremony	
121 racers	10:15	10:30	11:10	11:15	11:20	11:25	11:30	11:35	11:40	11:45	11:50	11:55	12:00	12:05	12:10	12:15	12:30	12:35	12:45

**EXAMPLE WORLD CUP SPRINT SCHEDULE (based on 2013 Clusone-presolana WC participation SM=35 SW=17 EM=15 EW=3 JM=16 JW=5)**

JUNIOR QUALIFICATIONS		JUNIOR FINALS		route open to senior		race closed to senior													
JW	JM	Final JW	Final JM	Flower ceremony															
21 racers	09:00	09:02	09:07	09:22	09:27	09:35	09:50												
SENIOR/ESPOIR QUALIFICATIONS		SENIOR/ESPOIR FINALS				route open to senior		race closed to senior											
SM	SW	1/4 final SW 1	1/4 final SW 2	1/4 final SW 3	1/4 final SW 4	1/4 final SW 5	1/4 final SM 1	1/4 final SM 2	1/4 final SM 3	1/4 final SM 4	1/4 final SM 5	1/2 final SW 1	1/2 final SW 2	1/2 final SM 1	1/2 final SM 2	Final SW	Final SM	Flower ceremony	
70 racers	10:00	10:17	10:24	<30 racers no 1/4 finals				10:39	10:44	10:49	10:54	10:59	11:04	11:09	11:14	11:19	11:34	11:39	11:49

Gap between heats : 05:00 min  
 Gap between qualif. and heats 15:00 min  
 Gap between 1/2 final and final 15:00 min  
 Gap between final and flower cer. 10:00 min



### 43. Appendix 32: Relay hand-over area

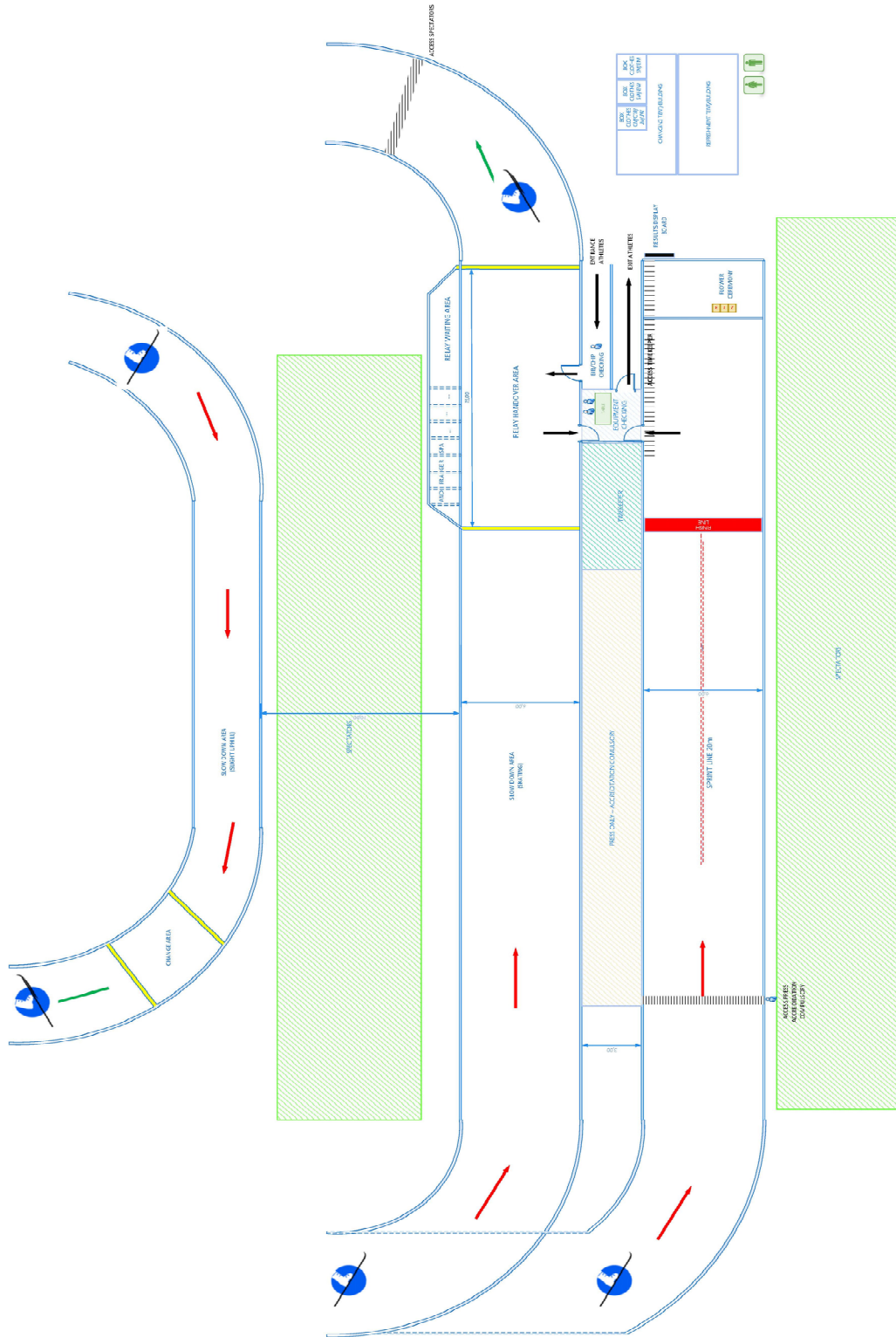

## 44. Appendix 33: Technical Specifications Refreshment Point

Schematic example of the organization of the start lines into the refreshment point. The implementation team of ISMF will adapt the Refreshment Point to the needs and the terrain.

### Refreshment Point

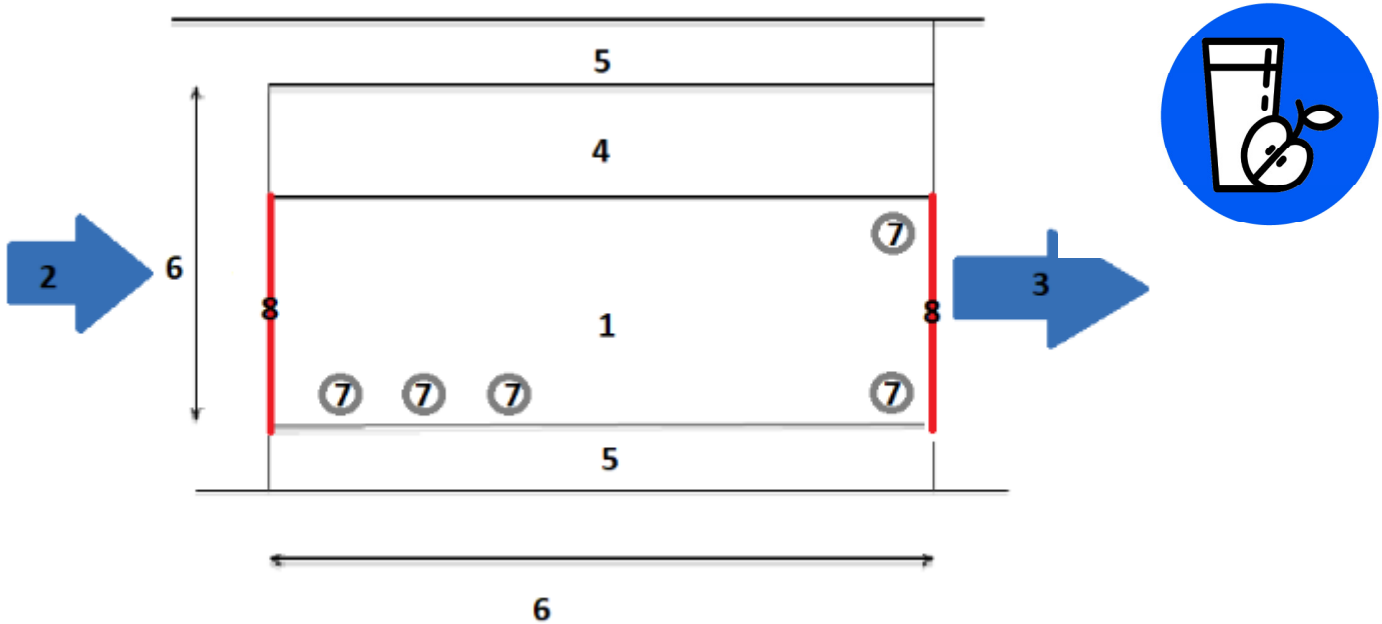

- 1 - Athletes refreshment zone
- 2 - Athletes/race track direction – entrance
- 3 - Athletes/race track direction – exit
- 4 - LOC and ISMF staff and National teams staff zone
- 5 - Security/Restricted zone (2-4m width)
- 6 – Recommended total measures: between 8-12m wide and between 15-20m long
- 7 – Trash bags
- 8 – Entrance/exit lines

\*\* The drawing is not at scale



## 45. Appendix 34: Control sheet

---

Name/number of checkpoint or waypoint: \_\_\_\_\_

Route: \_\_\_\_\_

Point chief: \_\_\_\_\_

Referees: \_\_\_\_\_

Rank	Hours	Minutes	Competitor		Rank	Hours	Minutes	Competitor	
			Num.	Comments				Num.	Comments
1					17				
2					18				
3					19				
4					20				
5					21				
6					22				
7					23				
8					24				
9					25				
10					26				
11					27				
12					28				
13					29				
14					30				
15					31				
16					32				

